

## Invitation for Bid

**Kitchen and Bath Improvements  
At Cottage City Community located  
4142 Bunker Hill Road, Cottage City, MD 20722  
IFB 2018-10R – (Reposted)**

For

Housing Authority of Prince George's County  
9200 Basil Court, Suite 500  
Largo, Maryland 20774



**EQUAL HOUSING  
OPPORTUNITY**

An Equal Opportunity Employer  
An Equal Housing Provider

BID NUMBER: IFB 2018-10R  
 BID DATE: October 05, 2018  
 PRE-BID MEETING October 10, 2018 at 10:00 AM

CONTACT:  
 MICHAEL JACKSON  
 301-883-5487  
[mjackson2@co.pg.md.us](mailto:mjackson2@co.pg.md.us)

## IFB 2018-10R INFORMATION AT A GLANCE

HAPGC CONTACT PERSON:	Michael Jackson, Project Manager Email: <a href="mailto:mjackson2@co.pg.md.us">mjackson2@co.pg.md.us</a> Phone: 301.883.5487
HOW TO OBTAIN THE IFB DOCUMENTS:	Visit HAPGC website ha.mypgc.us <a href="http://HA.mypgc.us">HA.mypgc.us</a>
IFB RELEASE DATE:	Friday, October 05, 2018
PRE-BID CONFERENCE: (JOB WALK) <b>NOTE: JOB WALK ATTENDANCE IS NOT MANDATORY BUT HIGHLY ENCOURAGED.</b> Prospective bidders should attend the pre-bid conference (job walk). The purpose is to consider prospective bidders questions and concerns on the proposed project(s).	<b>Wednesday, October 10, 2018 July 20, 2018        at 10:00 AM        Cottage City Towers        4142 Bunker Hill Road Cottage City , MD        20722</b>
DEADLINE FOR SUBMITTING QUESTIONS / REQUEST FOR INTERPRETATIONS: (RFIs)	<b>Friday, October 12, 2017at 1:00 PM</b>
BID SUBMITTAL DEADLINE	<b>Monday, October 15, 2018 at 1:00 PM</b> 9200 Basil Court, Suite 500 Largo, MD 20774 Bids shall be promptly opened in public at the above address.
BID OPENING:	<b>Monday, October 15, 2018 at 1:30 PM</b> 9200 Basil Court, Suite 208 Largo, MD 20774 Bids shall be promptly opened in public at the above address.

NOTE: HAPGC reserves the right to deviate from this timeline and/or modify the Scope of Work at any time

Notices of any such decisions or modifications will be located at:  
[HA.mypgc.us](http://HA.mypgc.us)

## **Section 1 - Administrative Information and Instructions for Bidders**

**1.1 Background.** The Housing Authority of Prince George’s County, Maryland (HAPGC) was established in 1969 to provide Prince George’s County residents with low to moderate incomes with safe, decent, and affordable housing. The HAPGC receives federal funds directly from the U.S. Department of Housing and Urban Development (HUD) to administer the Housing Choice Voucher program (HCV) and Public Housing Programs.. The HAPGC also provides its participant families with programs that encourage them to become self-sufficient which may potentially lead to homeownership opportunities.. The Housing Authority manages, five public housing residential sites consisting of 376 units. Additionally, the Housing Authority provides housing assistance to approximately 6000 families through the Housing Choice Voucher Program

**1.2 Official means of communication.** During the solicitation process for this IFB, all official communication with Bidders will be via notices posted on HAPGC website [ha.mypgc.us](http://ha.mypgc.us) [HA.mypgc.us](http://HA.mypgc.us). Notices may include any modifications to administrative or performance requirements, answers to inquiries received, clarifications to requirements, and the announcement of the apparent winning Bidder(s). It is incumbent upon Bidders to regularly monitor website for any such notices

**1.3 Description.** The work under this IFB shall be performed at the Cottage City Towers 4142 Bunker Hill Road, Cottage City, MD 20722 and shall include furnishing all labor, material, equipment, tools, supplies, services and incidentals, and performing all work necessary for the renovation of kitchen, baths, and flooring of ten (10) residential units to include two (2) Uniform Federal Accessibility Standard (UFAS) accessible residential units and associated improvements in strict conformance with all of the Contract documents. The work is to include the painting of each unit. All walls shall be cleaned, patched and painted

### **1.4 Schedule of Activities**

<b>Schedule of Activities - KEY DATES</b>			
1	Bid issuance	Fri, Oct 05, 2018	

2	Pre-Bid Meeting - Visit to Site	Wed, Jul 20, 2018	10:00 am	
3	All questions and requests for information - DUE	Fri, Oct 12, 2018	1:00 pm	
4	Response to questions and requests for information - DUE	Fri, Oct 12, 2018	5:00 pm	
5	Bid Closing - All Bids due	Mon, Oct 15, 2018	1:00 pm	
6	Bid Opening	Mon, Oct 15, 2018	1:30 pm	
7	Evaluation and Award	Thur, Oct 25, 2018	1:30 pm	
8	Project Kick-Off Meeting - HAPGC(DHCD)	Mon, Oct 29, 2018	2:00 pm	
9	Projected Project start date	Mon, Nov 05, 2018	2:00 pm	

Note: The HAPGC is requesting interested Bidders to send a “notice of intent to bid” via email to the Contract specialist, as shown in IFB Section 1.6 (Inquiries and Questions) below. This Bidder notification provides the HA with the level of interest for this solicitation. Not sending an intent-to-bid notice does NOT impact the Bidder’s eligibility to submit a bid by the bid submission deadline.

Inquiries and Questions. Bidders may submit email concerning this IFB to obtain clarification on specifications and requirements. All inquiries are due no later than the time shown in Section 1.4. (Schedule of Activities) or otherwise amended on-line. Reference the IFB number in the subject line, When submitting inquiries via email, use an attachment with plain text in WORD(.DOCX) format. List your questions as “1, 2, 3, etc.”

E-mail - Send to at [mjackson2@co.pg.md.us](mailto:mjackson2@co.pg.md.us) In the subject line, reference “IFB 2018-10R” Kitchen and Bath Improvements at Cottage City”

Response to Bidder questions (if required) will be published as a modification on HA website [HA.mypgc.us](http://HA.mypgc.us) in a timely manner. Bidders should not rely on information not published on website, during the open solicitation period. Bidders are responsible for monitoring HA website for the publication of any and all modifications to this solicitation.

**SECTION 2 HAPGC’S RESERVATION OF RIGHTS:**

**2.1 Right to Reject, Waive, or Terminate the IFB.** The HAPGC reserves the right to reject any or all bids, to waive any informality in the IFB process, or to terminate the IFB

process at any time, in its sole and absolute discretion, if deemed by the HAPGC to be in its best interests.

**2.2 Right to Not Award.** The HAPGC reserves the right not to award a contract pursuant to this IFB.

**2.3 Right to Terminate.** The HAPGC reserves the right to terminate a contract awarded pursuant to this IFB, at any time for its convenience upon five (5) calendar days written notice to the successful bidder(s).

**2.4 Right to Determine Time and Location.** The HAPGC reserves the right to determine the days, hours and locations that the successful bidder(s) shall provide the services called for in this IFB.

**2.5 Right to Determine Financial Responsibility and Viability.** The HAPGC reserves the right to require of bidder information regarding financial responsibility and viability or such other information as the HAPGC determines is necessary to ascertain whether a bid is in fact the lowest responsive and responsible bid submitted.

**2.6 Right to Retain Bids.** The HAPGC reserves the right to retain all written bids submitted to the HAPGC in response to this IFB, and not permit withdrawal of same for a period of 60 calendar days subsequent to the deadline for receiving said bids. The HAPGC may permit the withdrawal of bids when requested in writing by the bidder and such request is approved in writing by the HAPGC Contracting Officer (CO) in his/her sole and absolute discretion.

**2.7 Right to Reject Any Bid.** The HAPGC reserves the right to reject and not consider any bid that does not meet the requirements of this IFB, including but not necessarily limited to incomplete bids and/or bids offering alternate or non-requested services.

**2.8 No Obligation to Compensate.** The HAPGC shall have no obligation to compensate any bidder for any costs incurred in responding to this IFB.

**2.9 Right to Amend Prior to Award.** HAPGC reserves the right to, prior to award, revise, change, alter or amend any of the instructions, terms, conditions, and/or specifications identified within the IFB documents issued, within any attachment or drawing, or within any addenda issued. All addenda will be posted on HAPGC's website at [HA.mypgc.us](http://HA.mypgc.us). Such changes that are issued before the bid submission deadline shall be binding upon all prospective bidders. The HAPGC reserves the right to amend the contract any time prior to contract execution.

**2.10 Right to Prohibit.** The HAPGC shall reserve the right to at any time during the IFB or contract process to prohibit any further participation by a bidder or reject any bid submitted that does not conform to any of the requirements detailed herein. By accessing [HA.mypgc.us](http://HA.mypgc.us) and by downloading this document, each prospective bidder is thereby agreeing to abide by all terms and conditions listed within this document and

further agrees that he/she will inform the CO in writing within 5 calendar days of the discovery of any item listed herein or of any item that is issued thereafter by the HAPGC that he/she feels needs to be addressed. Failure to abide by this time frame shall relieve the HAPGC, but not the prospective bidder, of any responsibility pertaining to such issue.

**2.11 Right to Issue New Bids.** In the event the HAPGC rejects all bids submitted, the HAPGC reserves the right to re-advertise this IFB for new bids, to modify this IFB and re-advertise for new bids or to proceed to have the work completed otherwise.

**2.12 Right to Cancel Award.** HAPGC reserves the right to, without any liability; cancel the award of any bid(s) at any time before the execution of the contract documents by all parties.

**2.13 Right to Revise Quantities.** HAPGC reserves the right to reduce or increase estimated or actual quantities in whatever amount necessary without prejudice or liability to the HAPGC under the following conditions:

**2.13.1** Funding is not available;

**2.13.2** Legal restrictions are placed upon the expenditure of monies for this category of service or supplies; or,

**2.13.3** HAPGC's requirements in good faith change after the award of the contract.

**2.14 Right to Require Additional Information.** HAPGC reserves the right to require additional information from all prospective bidders to determine level of responsibility. Such information shall be submitted in the form and time frame required by HAPGC.

**2.15 Right to Require Accurate Timesheets.** HAPGC reserves the right to require the successful bidder to keep accurate timesheets for all employees assigned to perform Any project, task, or assignment resulting from this IFB and any resulting contract.

**2.16 Right to Contact.** HAPGC reserves the right to contact any individuals, entities, or organizations that have had a business relationship with the bidder regardless of their inclusion in the reference section of the bid submittal.

**2.17 Right to Seek Restitution.** In the event any contract resulting from this IFB is prematurely terminated due to nonperformance and/or withdrawal by the successful bidder, HAPGC reserves the right to seek monetary restitution (to include but not limited to withholding of monies owed) from the successful bidder to cover costs for interim services and/or cover the difference of a higher cost (difference between the terminated successful bidder's rate and new company's rate) beginning the date of successful bidder's termination through the contract expiration date.

**2.18 Right to Amend Prior to Contract Execution.** HAPGC reserves the right to amend the contract any time prior to contract execution.

**3.0 SCOPE OF WORK (SOW)/TECHNICAL SPECIFICATIONS (T/S):** The HAPGC is seeking bids from qualified, licensed and bonded entities to provide construction services at the public housing sites listed herein: SEE EXHIBIT 1

**Cottage City Towers  
4142 Bunker Hill Road,  
Cottage City, MD 20722**

The Housing Authority of Prince George's County is soliciting bids for the renovation/repair of ten (10) low rise housing units. The work will take place at our Cottage City Towers 4142 Bunker Hill Road, Cottage City, MD 20722. This work is being financed, in whole or in part, through grants provided by the Prince George's County Community Development Block Grant (CDBG) the U.S. Housing and Urban Development. The bidders are advised that Davis-Bacon labor standards will apply to this work. These labor standards require that workers receive no less than the prevailing wages. No bidder may withdraw their bid within 60 days after the date of the bid opening.

**3.1 Construction Planning:** All residential units will be un-occupied during the demolition and construction process. Contractor to provide scheduled work plan construction planning and scheduling MUST take into account that each resident requires 48 hours' notice prior to unit entry. Each resident MUST have a functioning stove, kitchen sink, bathroom and bedroom at the end of every work day. The HAPGC requires the successful bidder to have a complete construction plan schedule prior to starting work and to have that plan approved by the project manager or his designee, five (5) calendar days prior to the projected start date.

**3.2 GENERAL SPECIFICATIONS OF WORK:**

**3.2.1** The work under this IFB shall be performed at the Cottage City Towers 4142 Bunker Hill Road, Cottage City, MD 20722 and shall include furnishing all labor, material, equipment, tools, supplies, services and incidentals, and performing all work necessary for the renovation of kitchen, baths, and flooring of ten (10) residential units to include two (2) fully accessible residential units and associated improvements in strict conformance with all of the Contract documents, unless otherwise notated. The work is to include the painting of each unit. All walls shall be cleaned, patched and painted.

**3.2.2** Contractor to install **Owner supplied new cabinets, countertops, garbage disposal, stove and Refrigerator.** The Contractor to supply and install sink, faucet, and range hood. Sizes, color and model numbers per plans unless indicated otherwise.

Kitchen walls shall be cleaned, patched and painted before the installation of new cabinets, counters, fixtures and appliances.

**3.2.3 Contractor to supply and install new vanity and countertop with integral sink and cabinet in all bathrooms.** The Contractor to supply and install new ADA toilet, ADA faucet, grab bars. Sizes, color and model numbers shall be in accordance with the specifications, unless indicated otherwise. Walls shall be cleaned, patched and painted to match existing walls, if needed, before the installation of new cabinets, counters, fixtures.

**3.2.4 All equipment, cabinets, fixtures, appliances and finishes shall be new and not used or refurbished.** NOTE: Any "equivalent" new equipment, appliances, fixtures and finishes manufactured with similar specifications can be utilized for this project. Any other new product or brand that clearly or demonstrably meets the standards and specifications as outlined per plans, must be approved by the Project Manager prior to ordering.

**3.2.5 Contractor to provide residents with on-site storage facility of household items** Successful bidder to carefully remove and replace all furniture, appliances, and other large or bulk items and furniture as necessary to properly remove and install new flooring and complete all other renovations. Residents will be responsible for removing and boxing of all belongings i.e. clothing, dishware, food and smaller items inside cabinets and on countertops.

**3.2.6 OMIT**

**3.2.7 The four (4) handicap residential units to be renovated must meet UFAS requirements during all phases of work.**

**3.2.8 Successful bidder to ensure proper dumping of all waste and components from the site in an approved, legal landfill.** Successful bidder shall provide a cleared site free of all debris, contractor equipment, etc. off-site daily. HAPGC refuse containers may not be used for disposal of any waste.

**3.3 The HAPGC will give access to contractor for each unit based on contractor's proposed work schedule.** Forty-eight (48) hours' notice is required before entering each unit.

**3.4 Field Verification:** Successful bidder is responsible to field verify existing conditions and promptly notify the HAPGC if discrepancies in and omissions from the plans, specifications or other contract documents are found in the field, including unforeseen conditions that may affect the successful completion of the project and/or work. Contractors will have access to several units to verify square footage at pre-bid conference (job-walk).

**3.5 Explanations and Interpretations to Prospective Bidders:** Any prospective bidder desiring an explanation or interpretation of the solicitation, specifications, drawings, etc., must request it at least **ten (10) calendar days** before the scheduled time for bid opening. Requests may be oral or written. Oral requests must be confirmed in writing. The only oral clarifications that will be provided will be those clearly related to solicitation procedures, i.e., not substantive technical information. No other oral explanation or interpretation will be provided. Any information given a prospective bidder concerning this solicitation will be furnished promptly to all other prospective bidders as a written amendment to the solicitation, if that information is necessary in submitting bids, or if the lack of it would be prejudicial to other prospective bidders. Any information obtained by, or provided to, a bidder other than by formal amendment to the solicitation shall not constitute a change to the solicitation.

**3.6 Interpretation of the Documents:** Discrepancies in and omissions from the plans, specifications or other contract documents, or questions as to their meaning shall, at once, be brought to the attention of the HAPGC, Project Manager. Any interpretation of the documents will be made only by amendment duly issued and a copy of such amendment will be mailed or delivered to each person or firm receiving a set of such documents. The HAPGC will not be responsible for any other explanations or interpretations. Should anything in the scope of the work or any of the sections of the specifications be of such nature as to be apt to cause disputes between the various trades involved, such information shall be promptly called to the attention of the HAPGC.

**3.7 Amendments to the IFB:** If this solicitation is amended, then all terms and conditions which are not modified remain unchanged. Bidders shall acknowledge receipt of any amendment to this solicitation by signing and returning the amendment, by identifying the amendment number and date on the bid form, or by letter, telegram, or facsimile, if those methods are authorized in the solicitation. The HAPGC must receive acknowledgement by the time and at the place specified for receipt of bids. Bids which fail to acknowledge the bidder's receipt of any amendment will result in the rejection of the bid if the amendment(s) contained information which substantively changed the HAPGC's requirements. Amendments will be on file in the offices of the HAPGC at least 7 calendar days before bid opening.

**3.8 Caution to Bidders:** Prospective bidders are cautioned not to merely examine the plans and specifications in making their bid, since requirements are imposed upon the bidder by various other portions of this IFB and the Contract Documents.

#### **4.0 BID FORMAT:**

**4.1 Two-step Bid Submittal Process:** All bidders will initially submit the documentation/information detailed within the following listed **Step #1**. Then, the Authority will notify which bidders are to submit, within **5 days** after being

notified to do so, the information detailed within the following detailed Step #2 (the bidder(s) that are directed to submit information for Step #2 shall generally be apparent successful bidders that the HAPGC intends to award the contract).

**4.1.1 Tabbed Bid Submittal.** As may be further described herein, the Agency intends to retain a Contractor pursuant to a “Low Bid” basis, also taking into consideration responsiveness and responsibility. Therefore, so that the Agency can properly evaluate the offers received, all bids submitted in response to this IFB must be formatted in accordance with the sequence noted within the table below. Each category must be separated by numbered index dividers (which number extends so that each tab can be located without opening the bid) and labeled with the corresponding tab reference also noted below. None of the proposed services may conflict with any requirement the HAPGC has published herein or has issued by addendum.

Tab #	Description
1	Form of Bid: This Form is attached to this IFB document as Attachment A. Input the fee/bid amount, complete and execute where provided thereon and submitted under this tab as a part of the bid submittal.
2	Form HUD-5369-A (11/92), <i>Representations, Certifications and Other Statement of Bidders</i> : This Form is attached to this IFB document as Attachment B. This two (2) page Form must be fully completed, executed where provided thereon and submitted under this tab as a part of the bid submittal.
3	Form of Bid Bond: This Form is attached to this IFB document as Attachment C. Certificate as to Corporate Principal – this portion must be completed by the Secretary of the Corporation and the corporate seal affixed. Complete form and notarize. This 2-page Form must be fully completed, executed where provided thereon and submitted under this tab as a part of the bid submittal.
4	Section 3 Business Preference Documentation: For any bidder claiming a Section 3 Business Preference, he/she shall under this tab include the fully completed and executed Section 3 Business Preference Certification Form attached hereto as Attachment _1_ and any documentation required by that form. Note: If you qualify as a Section 3 Business Preference, your bid will receive a preference over other bids
5	Bid Submittal Binding Method: It is preferable and recommended that the bidder bind the bid submittal in such a manner that the HAPGC can, if needed, remove the binding (i.e. comb-type;” etc.) or remove the pages from the cover (i.e. 3-ring binder; etc.) to make copies then conveniently return the bid submittal to its original condition.

Tab #	Description
6	<b>Form of Non-Collusive Affidavit:</b> This Form is attached to this IFB document as Attachment <u>2</u> . Must check box indicating whether bidder is an individual, a corporation or partnership. Complete form and notarize. This 1-page Form must be fully completed, executed where provided thereon and submitted under this tab as a part of the bid submittal.
7	<b>Contractor Designation Form:</b> This Form is attached to this IFB document as Attachment <u>3</u> . This 2-page Form must be fully completed executed and submitted under this tab as a part of the bid submittal. NOTE: Bidders must also provide HAPGC with the name, contact information to include address, phone number, email address, core area of business, and years of expertise for each subcontractor and the minority status of each. This requested information is detailed in the Profile of Firm Form. This Form <b>MUST</b> be completed for each general and subcontractor and included in this Tab. Bidder remains responsible to HAPGC for any and all services and goods provided pursuant to this IFB and any resulting contract. If subcontractors will not be utilized, please check the appropriate box.
8	<b>Managerial Capacity:</b> The bidder entity must submit under this tab a concise description of its capacity to deliver the proposed services, including brief professional resumes for the persons identified within areas (5) and (6) of the <i>Contractor Designation Form (Attachment 3)</i> . Such information shall include the bidder's qualifications to provide the services; a brief description of the background and current organization of the firm.
9	<b>Equal Employment Opportunity Certification (Form HUD- 92010):</b> This Form is attached to this IFB document as Attachment <u>4</u> . The 2-page Form must be signed fully completed and submitted under this tab as a part of the bid submittal.
10	<b>Other Information (Optional Item):</b> The bidder may include hereunder any other general information that the bidder believes is appropriate to assist the HAPGC in its evaluation.
	<b>Insurance Certificates.</b> The apparent successful bidder will also direct its insurance broker or carrier to deliver directly to the Agency (by email is preferred) the insurance certificates detailed within the following Sections 6.2.1 through 6.2.5 herein. NOTE: The apparent successful bidder will NOT deliver these certificates—the insurance broker or carrier will do so.

**4.2 Bidder's Security:** Bids in excess of twenty-five thousand dollars (\$25,000) shall be accompanied by a bid guarantee of not less than ten percent (10%) of the amount of

the bid, including the aggregate of all separate bid items and schedules covered by the bid, which may be: bid bond, money order, certified check or bank draft, U.S. Government Bonds at par value, or a bid bond secured by a surety company acceptable to the U.S. Government and authorized to do business in the state where the work is to be performed. **The Form of Bid Bond (Attachment \_5\_) must be fully completed, executed and notarized where provided thereon and submitted under tab 3 (above) as a part of the bid submittal.** Said check or bond shall be made payable to the HAPGC and shall be given as a guarantee that the Bidder, **if awarded the Work, will enter into an Agreement with the HAPGC and will furnish the necessary insurance certificates, Payment Bond, and Performance Bond.** Each of said bonds and insurance certificates shall be in the amounts of stated in the Standard Specifications or Special Provisions. In case of refusal or failure of the successful Bidder to enter into said Agreement, the check or Bid Bond, as the case may be, shall be forfeited to the HAPGC. If the Bidder elects to furnish a Bid Bond as its security, the Bidder shall use the Bid Bond from bound herein, or one conforming substantially to it in form.

**4.3 Davis-Bacon Act Wage Determination:** For all construction contracts awarded by in excess of \$2,000, when required by Federal Grant Program legislation, Contractor hereby agrees to comply with the Davis-Bacon Act (40 U.S.C, 276a to 276a-7) as supplemented in Department of Labor Regulations (29 CFR Part 5). Therefore, by submitting a bid, each bidder is thereby agreeing to and verifying that he/she will not pay his/her employees less than the wage rate listed in the following table. Therefore, it shall be mandatory upon the contractor to whom the contract is awarded, and upon each subcontractor under him, to pay all laborers and workmen employed in the execution of the contract not less than the applicable wage rates for each craft or type of laborer or workman so employed. **SEE EXHIBIT 2**

General Decision #	Wage Decision #	Mod #	Revision Date
MD20170058	MD180058	MD58	09/28/2018

**4.4 Wage Decision Effective Date (“Lock-In” Date):** General wage decisions shall be locked-in on the date bids are opened (bid opening date) provided that the contract is awarded within 90 days after bid opening. However, if the contract is awarded more than 90 days after the bid-opening, the contract award date “locks-in” the wage decision. For contracts, purchase orders or other agreements for which there is no bid opening or award date, the construction start date is the lock-in date (HUD Handbook 1344.1, REV 2).

**4.5 Preemption of State Prevailing Wage Requirements:** A prevailing wage rate (including basic hourly rate and any fringe benefits) determined under State law to be prevailing with respect to an employee in any trade or position employed under the contract shall be inapplicable to a contract or HAPGC performed work item for the development, maintenance, and modernization of a project (24 CFR Part 965.101).

**4.6 Bid Submission:** All bids must be submitted and time-stamped received in the designated HAPGC office by no later due no later than the time shown in Section 1.4. (Schedule of Activities) or otherwise amended on-line (or within any ensuing amendment). A total of one (1) original signature copy (marked "ORIGINAL" and "SEALED BID") of the bid submittal shall be placed unfolded in a sealed package and addressed to:

**Housing Authority of Prince George's County (HAPGC)  
Attention: Eric C. Brown, Executive Director  
9200 Basil Court, Suite 500  
Largo, MD 20774**

The package exterior must clearly include the following, " **IFB NO. 2018-10R Kitchen & Bathroom Renovation Project at Cottage City**" and must have the bidder's name and return address. Bids received after the published deadline will not be accepted. Email delivery shall not be a substitute for or waive physical delivery of the bid by the deadline.

**4.7 Bid Acceptance Period:** The acceptance period is the number of calendar days available to the HAPGC for awarding a contract from the date specified in this solicitation for receipt of bids. The HAPGC requires a minimum acceptance period of **ninety 90 calendar days**. A bid allowing less than the HAPGC's minimum acceptance period will be rejected.

**4.8 Submission Conditions:** DO NOT FOLD OR MAKE ANY ADDITIONAL MARKS, NOTATIONS OR REQUIREMENTS ON THE DOCUMENTS TO BE SUBMITTED! Bidders are not allowed to change any requirements or forms contained herein, either by making or entering onto these documents or the documents submitted any revisions or additions; and if any such additional marks, notations or requirements are entered on any of the documents that are submitted to the HAPGC by the bidder, such may invalidate that bid. If, after accepting such a bid, the HAPGC decides that any such entry has not changed the intent of the bid that the HAPGC intended to receive, the HAPGC may accept the bid and the bid shall be considered by the HAPGC as if those additional marks, notations or requirements were not entered on such. By accessing the noted Internet Site, registering and downloading these documents, each prospective bidder that does so is thereby agreeing to confirm all notices that the HAPGC delivers to him/her as instructed, and by submitting a bid, the bidder is thereby agreeing to abide by all terms and conditions published herein and by amendment pertaining to this IFB.

**4.9 Submission Responsibilities:** It shall be the responsibility of each bidder to be aware of and to abide by all dates, times, conditions, requirements and specifications set forth within all applicable documents issued by the HAPGC, including the IFB document, the documents listed in the attachments section, and any amendments and required attachments submitted by the bidder. By virtue of completing, signing and submitting the completed documents, the bidder is stating his/her agreement to comply with the all conditions and requirements set forth within those documents. Written notice

from the bidder not authorized in writing by the Executive Director to exclude any of the HAPGC requirements contained within the documents may cause that bidder to not be considered for award.

**4.10 Bidder's Responsibilities; Contact With the HAPGC:** It is the responsibility of the bidder to address all communication and correspondence pertaining to this IFB process to the Executive Director only. Bidders must not make inquiry or communicate with any other HAPGC staff member or official (including members of the Board of Commissioners) pertaining to this IFB. Failure to abide by this requirement may be cause for the HAPGC to not consider a bid submittal received from any bidder who may have not abided by this directive.

**4.11 Responsibility for Subcontractors:** All requirements for the "Prime" contractor shall also apply to any and all subcontractors. It is the Prime Contractors' responsibility to insure the compliance of the subcontractors. Regardless of subcontracting, the Prime Contractor remains liable to HAPGC for the performance under this IFB or any resulting contract.

**4.12 Invitations for Bids (IFB) Amendments:** If this solicitation is amended, then all terms and conditions which are not modified remain unchanged. Bidders shall acknowledge receipt of any amendment to this solicitation by signing and returning the amendment, by identifying the amendment number and date on the bid form by email, letter, or facsimile. The HAPGC must receive acknowledgement by the time and at the place specified for receipt of bids. Bids which fail to acknowledge the bidder's receipt of any amendment will result in the rejection of the bid if the amendment(s) contained information which substantively changed the HAPGC's requirements. Amendments will be on file in the offices of the HAPGC and at least **seven (7) calendar days** prior to bid opening. All questions and requests for information must be addressed in writing to the

**4.13 Pre-bid Conference (Job Walk):** The scheduled pre-bid conference/job walk is not mandatory. Many prospective bidders have previously responded to an IFB with a multi-tabbed submittal and feel comfortable in doing so without attending the pre-bid conference. Typically, such conferences last one (1) hour or less, though such is not guaranteed. The purpose of this conference is to assist prospective bidders to have a full understanding of the IFB documents so that he/she feels confident in submitting an appropriate bid; therefore, at this conference the HAPGC will conduct a brief overview of the IFB documents, including the attachments. Prospective bidders may also ask questions, though the Contracting Officer may require that some such questions are delivered in writing prior to a response being delivered. Whereas the purpose of this conference is to review the IFB documents, attendees should bring a copy of the IFB documents to this conference; the HAPGC **will not** distribute at this conference any copies of the IFB documents.

## **5.0 BID EVALUATION:**

**5.1 Public Opening:** At the set date and time, all bids received will be opened and publicly read aloud by the Contracting Officer, including the company name of the bidder and the total calculated costs proposed. At the bid opening the HAPGC will only disclose the following information: (a) The company name of each bidder; (b) the calculated total amount bid; and (c) the identity of the apparent lowest bidder. A copy of the bid tabulation or recap recorded will be made available to each member of the public attending such opening and to anyone who requests such afterwards. The bids will not be made available for inspection by anyone at this time. The HAPGC will, at a later time, review all bids in detail and will notify all bidders of any bidder that is, as a result of the more detailed inspection of bids submitted, ruled to be non-responsive or not-responsive. The HAPGC reserves the right to, as determined by the HAPGC, "waive informalities and minor irregularities" in the offers received.

**5.1.1 Ties:** In the case of tie bids, the award shall be decided by "drawing lots or other random means of selection."

**5.2 Responsive Bid Evaluation:** After the public opening of bid submittals, all bids received will later be evaluated by the Contracting Officer for responsiveness, starting with the apparent lowest bidder. Bids not meeting the IFB's listed minimum requirements are deemed to be non-responsive and shall not be considered further. The Contracting Officer may then consider the next apparent lowest bidder, in his/her sole and absolute discretion. The non-responsive bidder will be notified of such in writing by the HAPGC in a timely manner.

**5.3 Responsible Bidder Evaluation:** Once a bid is determined to be responsive to the IFB, the Contracting Officer will then evaluate the apparent lowest responsive bidder to ensure that he/she or their firm is responsible. If the Contracting Officer ascertains that such person or firm is responsible, as defined below in Section 5.3.1, the Contracting Officer may then proceed with a notice of intent to award. If the Contracting Officer determines that such person or firm is deemed to be not responsible, in his/her sole and absolute discretion, they will be notified of such in writing by the HAPGC in a timely manner. The non-responsive bidder may request further information and a hearing; in such case the Contracting Officer may proceed with the noted Responsive and Responsible Evaluations with the next apparent lowest bidder.

### **5.3.1 Responsible Bidder Requirements:**

- Have adequate financial resources to perform the contract, or the ability to obtain them;
- Have all necessary and required insurance coverage as listed in the IFB, or the ability to obtain such;
- Have the necessary organization, experience, accounting and operational controls, and technical skills, or the ability to obtain them;

- Have the necessary management, recruitment sources, personnel and/or training facilities, or the ability to obtain them;
- Be able to comply with the required delivery and performance schedule, taking into consideration all existing commercial and/or governmental business commitments;
- Have a satisfactory performance record in placement of qualified personnel;
- Have a satisfactory record of integrity and business ethics, and;
- Be otherwise qualified and eligible to receive an award under all applicable laws and regulations, including not being debarred or suspended under a HUD imposed Limited Denial of Participation (LDP). Be advised that all persons or contractors that have been suspended or debarred from Federal programs will be indicated as such in the System for Award Management (SAM).

**5.3.2 Additional Evidence of Responsibility:** The HAPGC reserves the right to request additional information whether in writing or by oral presentation in order to further determine the successful bidder's responsibility. Failure to provide adequate documentation within the specified time period will result in the successful bidder being determined as non-responsible. Additional steps or information may include, but are not limited to:

- Copies of financial statements, credit bureau reports, lines of credit and/or account balances with the successful bidder's financial institutions and/or a breakdown of his/her material costs.
- Copies of any business audits or financial reports.
- Lists of other contracts completed and contact information on past customers.
- A list of all personnel and their requisite experience as it relates to this IFB that are currently available to work.

**5.4 Restrictions:** Any and all persons having ownership interest in a bidder entity or familial (including in-laws) and/or employment relationships (past or current) with principals and/or employees of a bidder entity will be excluded from participation in the evaluation of the bid.

**5.5 Bid Protest:** Any prospective or actual bidder, who is allegedly aggrieved in connection with the solicitation of a bid or award of a contract, shall have the right to protest. To be eligible to file a protest with the HAPGC pertaining to an IFB or contract, the alleged aggrieved protestant must have been involved in the IFB process in some manner as a prospective bidder (i.e. registered and received the IFB documents) when the alleged situation occurred. The alleged aggrieved protestant must file, in writing, to HAPGC the exact reason for the protest, attaching any supportive data. The protestant must state within the written protest document specifically (not by inference) what action by HAPGC or condition is being protested as inequitable, making, where appropriate specific reference to the IFB documents issued and including the specific citation of law, rule, regulation, or procedure upon which the protest is based. The protest document

must also state the corrective action requested. Failure by the alleged aggrieved protestant to fully submit such information shall relieve HAPGC from any responsibility to take any corrective action, and as a result of noncompliance, the appeal will be dismissed without further review. The HAPGC has no obligation to consider a protest filed by any party that does not meet these criteria. Any protest against a solicitation must be received before the due date for the receipt of bids, and any protest against the award of a contract must be received within ten (10) calendar days after the successful bidder receives notice of the contract award, or the protest will not be considered. All bid protests shall be in writing, submitted to the Contracting Officer or designee, who shall issue a written decision on the matter. The Contracting Officer may, at his/her discretion, suspend the procurement pending resolution of the protest if the facts presented so warrant. All appeals shall be marked as follows and sent to the address listed below:

**APPEAL OF IFB NO. 2018-10R  
HAPGC Eric C. Brown, Contracting Officer  
9200 Basil Court, Suite 500  
Largo, MD. 20774**

## **6.0 CONTRACT AWARD:**

**6.1 Lowest Responsive and Responsible Bidder:** An award of a contract pursuant to this IFB, if determined to be in the best interest of the HAPGC to do so, will be made to the responsive and responsible bidder that submits the lowest cost; in this case, the lowest calculated cost.

**6.1.1 Basis for Determining Lowest Bid:** The lowest bid shall be the lowest total of the base bid amounts on the base contract.

**6.2 Contract Award Procedure:** If a contract is awarded pursuant to this IFB, the following detailed procedures will be followed:

**6.2.1** By completing, executing and submitting the Form of Bid, Attachment 6, the successful bidder is thereby agreeing to "abide by all terms and conditions pertaining to this IFB

**6.2.2** Depending on the amount of the award (typically for amounts greater than \$100,000), the HAPGC will forward the contract to the HAPGC Board of Commissioners (BOC) for approval prior to signing the contract with the lowest responsive and responsible bidder.

**6.2.3** The contract shall be awarded upon a resolution or minute order to that effect duly adopted by the HAPGC BOC, in their sole and absolute discretion. Execution of the contract documents shall constitute a written memorial thereof.

**6.3 Contract Conditions:** The following provisions are considered mandatory conditions of any contract award made by the HAPGC pursuant to this IFB:

**6.3.1 Contract Form:** By responding to this IFB and submitting a bid, the successful bidder acknowledges and agrees that HAPGC will only execute agreements prepared by HAPGC which are substantially approved as to form and substance by HAPGC. The HAPGC WILL NOT execute the successful proposer's contract form. Any proposer that does not feel the listed contract clauses or specifications are reasonable or complete shall address such with the HAPGC in writing during the bidding period (prior to the posted bid submittal deadline). HAPGC will consider such clauses and determine in its sole and absolute discretion, whether or not to amend the contract if deemed by the HAPGC to be in its best interests. **Please note that the HAPGC has no legal right or ability to (and will not) at any time negotiate any clauses contained within ANY of the HUD forms included as a part of this IFB.**

**6.3.2 Assignment of Personnel:** The HAPGC shall retain the right to demand and receive a change in personnel assigned to the work if the HAPGC believes that such change is in the best interest of the HAPGC and the completion of the contracted work.

**6.4 Contract Period (Time of Completion):** The successful bidder agrees to commence work no later than **seven (7) calendar days** after the commencement date specified in the **Notice to Proceed (NTP)** and to fully complete the project within **Ninety (90) calendar days**. The NTP is the written notification from the HAPGC giving the contractor notice to commence with the project. The NTP will specify project details such as the mobilization start date, construction start date, and work completion date. **NOTE:** The timeframe for ordering and delivery of supplies and/or materials is typically not included with the issuance of the NTP. The NTP is issued once HAPGC staff and the contractor have mutually agreed to commence construction, installation, erection, alteration, repair and demolition activities.

**6.4.1 Liquidated Damages:** If the Contractor fails to complete the work within the time specified in the contract, or any extension, as specified in the clause entitled Default of this contract, the Contractor shall pay to the HAPGC as liquidated damages, the sum of **\$300.00** for each day of delay.

**6.4.2 Temporary Delay:** The HAPGC may withhold issuance of the NTP for a period not to exceed **ninety (90) calendar days** after the construction Contract is executed.

**6.4.3 Time of the Essence:** Time is of the essence as to each provision in which a timeframe for performance is provided in this IFB. Failure to meet these timeframes may be considered a material breach, and HAPGC may pursue compensatory and/or liquidated damages under the contract.

**6.5 Execution of Work:** All work is to be performed by qualified, competent trained personnel. The contractor is to be licensed and responsible for providing supervision of the work by appropriately identified personnel. The HAPGC may require the contractor to remove from the work such employees as the local authority deems incompetent, careless, insubordinate, or otherwise objectionable, or whose continued employment on the work is deemed by the HAPGC to be contrary to the public interest. The contractor shall ensure full cooperation of all workers and suppliers and shall be confined to this work only. The contractor and his personnel shall respect the rights of tenants in the surrounding dwellings where work is being performed. The office hours for all locations of the HAPGC are 8:00 am – 5:00 pm Monday through Friday, or as otherwise specified in the Scope of Work. The contractor's working hours may vary depending upon the type of work being performed. Contractor may work longer hours if approved in advance by the HAPGC.

**6.6 Warranty:** All items installed/provided under any contract resulting from this IFB must include a minimum of a one (1) year warranty from the Contractor for labor, materials, and installation except as specified otherwise herein. The period will begin on the date of "FINAL" acceptance by HAPGC.

**6.6.1** The services provided under the contract shall conform to all information contained within the IFB documents as well as applicable Industry Published Technical Specifications, and if one of the above mentioned Specifications contains more stringent requirements than the other, the more stringent requirements shall apply.

**6.6.2** In addition to all other warranties, the warranty shall include the warranty for merchantability and the warranty of fitness for a particular purpose.

**6.6.3 Assignment of Warranty:** Contractor shall assign any warranties and guarantees to HAPGC and provide the Contractor's Warranty for Labor and Installation to HAPGC along with all Manufacturers' Warranty documents.

## **7.0 PROMPT ACTION BY SUCCESSFUL BIDDER:**

**7.1.1** Upon issuance of the Notice of Award or Notice of Intent to Award, the successful bidder will have **seven (7) calendar days** to supply a payment/performance bond and furnish insurance documents in accordance with the Contract Documents.

**7.1.2 Assurance of Completion (Performance Bond & Payment Bond):** The successful bidder shall furnish an assurance of completion prior to the execution of the construction contract. This assurance shall be a performance and payment bond in a penal sum of 100 percent of the contract price.

**7.1.3 Security substitutions for monies withheld to insure the contractor's performance:** The Contractor at his request and expense will be permitted to substitute equivalent securities for any monies withheld to insure performance.

**7.2 Licensing and Insurance Requirements:** Prior to contract award (but not as a part of the bid submission) the *successful bidder* will be required to provide:

**7.2.1 Insurance:** Without limiting or diminishing the Contractor's obligation to Indemnify or hold the Authority harmless, Contractor shall procure and maintain or cause to be maintained, at its sole cost and expense, the following insurance coverages during the term of this Contract. As respects to the insurance section only, the Authority herein refers Board of Commissioners, employees, as Additional Insureds

**7.2.2 Workers' Compensation:** If the Contractor has employees as defined by the State of Maryland, the Contractor shall maintain statutory Workers' Compensation Insurance as prescribed by the laws of the State of Maryland. Policy shall include Employers' Liability (Coverage B) including Occupational Disease with limits not less than \$1,000,000 per person per accident. The policy shall be endorsed to waive subrogation in favor of the Authority; and, if applicable, to provide a Borrowed Servant/Alternate Employee Endorsement.

**7.2.3 Commercial General Liability:** Commercial General Liability insurance coverage, including but not limited to, premises liability, unmodified contractual liability, products and completed operations liability, personal and advertising injury, employment practices liability, and cross liability coverage, covering claims which may arise from or out of Contractor's performance of its obligations hereunder. Policy shall name the Authority, Board of Commissioners, employees, as Additional Insureds. Policy's limit of liability shall not be less than \$1,000,000 per occurrence combined single limit. If such insurance contains a general aggregate limit, it shall apply separately to this Contract or be no less than two (2) times the occurrence limit

**7.2.4 Vehicle Liability:** If vehicles or mobile equipment are used in the performance of the obligations under this Contract, then Contractor shall maintain liability insurance for all owned, non-owned or hired vehicles so used in an amount not less than \$1,000,000 per occurrence combined single limit. If such insurance contains a general aggregate limit, it shall apply separately to this Contract or be no less than two (2) times the occurrence limit. Policy shall name the Authority, Board of Commissioners, employees, as Additional Insureds.

**7.2.5 General Insurance Provisions - All lines:**

a. Any insurance carrier providing insurance coverage hereunder shall be admitted to the State of Maryland and have an A M BEST rating of not less than A:VIII (A:8) unless such requirements are waived, in writing, by the HAPGC. If the HAPGC waives a requirement for a particular insurer such waiver is only valid for that specific insurer and only for one policy term.

b. Contractor shall cause Contractor's insurance carrier(s) to furnish the Authority with either 1) a properly executed original Certificate(s) of Insurance and certified original copies of Endorsements effecting coverage as required herein, and 2) if requested to do so orally or in writing by the Authority, provide original Certified copies of policies including all Endorsements and all attachments thereto, showing such insurance is in full force and effect. Further, said Certificate(s) and policies of insurance shall contain the covenant of the insurance carrier(s) that thirty (30) days written notice shall be given to the Authority prior to any material modification, cancellation, expiration or reduction in coverage of such insurance. In the event of a material modification, cancellation, expiration, or reduction in coverage, this Contract shall terminate forthwith, unless the Authority receives, prior to such effective date, another properly executed original Certificate of Insurance and original copies of endorsements or certified original policies, including all endorsements and attachments thereto evidencing coverage's set forth herein and the insurance required herein is in full force and effect. **Contractor shall not commence operations until the Authority has been furnished original Certificate (s) of Insurance and certified original copies of endorsements and if requested, certified original policies of insurance including all endorsements and any and all other attachments as required in this Section, showing that such insurance is in full force and effect. An individual authorized by the insurance carrier to do so on its behalf shall sign the original endorsements for each policy and the Certificate of Insurance.**

c. Contractor shall pass down the insurance obligations contained herein to all tiers of subcontractors working under this Contract.

d. Contractor agrees to notify Authority of any claim by a third party or any incident or event that may give rise to a claim arising from the performance of this Contract.

**7.3 Business License:** A copy of the bidder's business license allowing that entity to provide such services within the State of Maryland.

**7.4 Contract Service Standards:** All work performed pursuant to this IFB must conform and comply with all applicable local, state and federal codes, statutes, laws and regulations.

## **8.0 ADDITIONAL CONSIDERATIONS**

**8.1 Work on HAPGC Property:** If the successful bidder's work under the contract involves operation on HAPGC premises, the successful bidder shall take all necessary precautions to prevent the occurrence of any injury to persons or property during the progress of such work and shall immediately return said property to a condition equal to or better than the existing condition prior to the commencement of work at the site at no cost to HAPGC.

**8.2 Subcontractors:** Unless otherwise stated within the IFB documents, the successful bidder may not use any subcontractors to accomplish any portion of the services described within the IFB documents or the contract without the prior written permission of the HAPGC. Also, any substitution of subcontractors must be approved in writing by HAPGC prior to their engagement.

**8.3 Salaries and Expenses Relating to the Successful Bidders Employees:** Unless otherwise state within the IFB documents, the successful bidder shall pay all salaries and expenses of it employees including but not limited to all applicable Federal, Social Security taxes, Federal and State unemployment taxes and any similar taxes relating to its employees or other personnel furnished under this contract.

**The Housing Authority of Prince George's County  
Section 3 Clause**

**TABLE OF CONTENTS:**

**SECTION 3 CLAUSE** ..... - 1 -

**A.-E. Purpose/General Requirements** ..... - 1 -

**F. Section 3 Regulations (numerical goals)** ..... - 2 -

**G. Resident Relations**..... - 2 -

**H. Geographical Area Tier System: (starting point for residents)**..... - 2 -

**I. Hiring and Contracting Obligations (Section 3 / Business Concerns)** ..... - 3 -

**J. Section 3 Applicants Proving Eligibility** ..... - 3 -

**K. Training Fund** ..... - 3 -

**L. Preference for Section 3 Certified Contractors** ..... - 4 -

**M. Section 3 Business Concern** ..... - 4 -

**N. Fines for Non-Compliance** ..... - 5 -

**O. Contractors that are Unable to Engage in Opportunities for Section 3/Business** ..... - 5 -

**P. Section 3 Joint Venture** ..... - 5 -

**SECTION 3 RESIDENT SELF CERTIFICATION FORM** ..... - 6 -

**SECTION 3 CONTRACTOR'S CERTIFICATION** ..... - 7 -

**ASSURANCE OF COMPLIANCE (Section 3, HUD ACT of 1968)** ..... - 8 -

**E-MAIL/CONTACTS** ..... - 9 -

## **SECTION 3 CLAUSE**

The Housing Authority of Prince George's County will provide to each Solicitation Bid, A copy of the Section 3 Clause in relation to the Section 3 requirements under the Housing and Urban Develop Project Management act of 1968, as amended, 12 U.S.C. 1701u (Section 3).

### **A.-E. Purpose/General Requirements**

**A.** The work to be performed in connection with the underlying contract is subject to the requirements of Section 3 of the Housing and Urban Development Project Management Act of 1968, as amended, 12 U.S.C. 1701u (Section 3). The purpose of Section 3 is to ensure that employment and other economic opportunities generated by HUD assistance or HUD-assisted projects covered by Section 3 should if possible and to the greatest extent feasible, be directed to low and very low income persons, particularly persons who are recipients of HUD assistance for housing.

**B.** The parties to the underlying contract agree to comply with HUD's regulations in 24 CFR, Part 135, which implements Section 3. As evidenced by their execution of the Section 3 certification, the parties to the underlying contract certify that they are under no contractual or other impediment that would prevent them from complying with the Part 135 Regulations.

**C.** The contractor agrees to send to each labor organization or representative of workers with which the contractor has a collective bargaining agreement or other understanding, if any, a notice advising the labor organization or worker's representative of the contractor's commitments under this Section 3 Clause, and will post copies of the notice in conspicuous places at the work site where both employees and applicants for training and employment positions can see the notice. The notice shall describe the Section 3 Preference, shall set forth the minimum number of positions and job titles subject to hire, the availability of apprenticeship and training positions along with qualifications for each, the name and location of the person(s) taking applications for each of the positions, and the anticipated date the work shall begin.

- D.** The contractor agrees to include this Section 3 Clause in every subcontract subject to compliance with regulations in 24 CFR part 135, and agrees to take appropriate action, as provided in an applicable provision of the subcontract or in this Section 3 Clause, upon a finding that the subcontractor is in violation of the regulations in 24 CFR Part 135. The contractor will not subcontract with any subcontractor where the contractor has notice or knowledge that the subcontractor has been found in violation of the regulations in 24 CFR, part135.
- D.** The contractor agrees to include this Section 3 Clause in every subcontract subject to compliance with regulations in 24 CFR part 135, and agrees to take appropriate action, as

provided in an applicable provision of the subcontract or in this Section 3 Clause, upon a finding that the subcontractor is in violation of the regulations in 24 CFR Part 135. The contractor will not subcontract with any subcontractor where the contractor has notice or knowledge that the subcontractor has been found in violation of the regulations in 24 CFR, part135.

**E.**

The contractor will certify that any vacant employment positions, including training positions, that are filled: (1) after the contractor is selected but before the contract is executed, and (2) with persons other than those to whom the regulations of 24 CFR part 135 require employment opportunities to be directed, were not filled to circumvent the contractor's obligations under 24 CFR, part 135.

**Noncompliance with HUD's regulations in 24 CFR part 135 may result in sanctions, termination of the underlying contract for default, and debarment or suspension from future HUD assisted contracts.**

**F. Section 3 Regulations (numerical goals)**

1. When contractors and/or sub-contractor triggers the Section 3 regulations by adding new hires, the contractors and/or sub-contractors are required, to the greatest extent feasible, to initially, reach out to the residents of the Authority concerning the opportunity for employment, contracts and/or training, thereafter the contractors and/or sub-contractors must direct these opportunities to other low income people in the community where the project is located.

2. All contractors and/or sub-contractors that trigger the Section 3 regulations, must document every effort that was made to offer and fill the employment, contract and/or training opportunity with a Section 3 person or business.

3. The minimum requirements for documenting solicitation of a Section 3 person or business include: distributing flyers, placing ads, local media, community organizations, and posting signs in the resident relations office, community rental offices and in and around the community where the covered contract has been awarded. (Refer to H. "Geographical Area Tier System" below for a description of the required solicitation area and individuals)

4. The contractors and/or sub-contractors must prove that he or she has made every effort to notify The Authority's residents, those Section 3 residents within a 15 mile radius of the covered contract area, and those Section 3 residents within the current metropolitan service area in which the covered contract lies of the contractors opportunities for employment, contracts, and/or training. If the contractors and/or sub-contractors prove these efforts and the contractors and/or sub-contractors were unable to solicit Section 3

persons or businesses, then at that time the contractors and/or sub-contractors may open up these opportunities to other non-Section 3 persons or contractors.

5. Documentation of all contractors and/or sub-contractors efforts to provide employment, contracts, and/or training to Section 3 persons or businesses must be presented to the Section 3 compliance office before moving forward.

6. All contractors and/or sub-contractors that have not met the Section 3 regulations set forth in this section have the burden of demonstrating why it was not feasible to meet these regulations.

7. Section 3 regulations are mandated by HUD and are required by all contractors and/or subcontractors. Noncompliance with HUD's regulations in 24 CFR part 135 may result in sanctions, termination of the contract for default, and debarment or suspension from future HUD assisted contracts.

**G. Resident Relations**

Contractors and/or sub-contractors may contact the Housing Authority of Prince George's County for possible Section 3 applicants, business concerns and joint venture candidates for hire.

**H. Geographical Area Tier System: (starting point for residents)**

1. The Housing Authority of Prince George's County residents & Section 8 residents
2. The 15 mile radius surrounding the covered contract area
3. Current MSA (Metropolitan Service Area) in which the contract lie

**I. Hiring and Contracting Obligations (Section 3 / Business Concerns)**

**Hiring Obligation**

To the greatest extent feasible, all contractors and/or sub-contractors who are a party to the underlying Section 3 covered contract will commit to hiring 30 percent of Section 3 new hires, or maintaining at least 30 percent full time permanent employees that are Section 3 residents within 3 years of being employed. Contracting Obligation to the greatest extent feasible, all contractors and/or sub-contractors who are a party to the underlying contract will commit to awarding at least 10 percent of the total contract amount to Section 3 business concerns, and at least 3 percent of the total contract amount of all covered no construction contracts to be awarded to Section 3 business concerns.

**J. Section 3 Applicants Proving Eligibility**

A person seeking the training and employment preference provided by Section 3 covered assistance has the responsibility of providing evidence (if requested) that the person is eligible for the preference. The willful falsification of an individual's Section 3 status may

subject the Individual to civil or criminal prosecution. (See, 18 USC § 1001 and 31 USC § 231) Nothing will be construed to require the employment of a Section 3 resident who does not meet the qualifications of the position to be filled.

#### **K. Training Fund**

As an alternative, Section 3 compliance can be archived by contributing into the Housing Authority's Section 3 Training fund in the amount specified in the section below. This does not apply to sub-contractors. This applies to the base contract amount for the prime contractor and is not assessed to subsequent change orders or addendums.

**When the contract amount is less than \$100,000**

5 % of base contract  
 At least \$100,000, but less than \$200,000  
 4.5 % of base contract  
 At least \$200,000, but less than \$300,000  
 4 % of base contract  
 At least \$300,000, but less than \$400,000  
 3.5 % of base contract  
 At least \$400,000, but less than \$500,000  
 3 % of base contract  
 At least \$500,000, but less than \$1 million  
 2.5 % of base contract  
 At least \$1 million, but less than \$2 million  
 2 % of base contract  
 At least \$2 million, but less than \$4 million  
 1.5 % of base contract  
 At least \$4 million, but less than \$7 million  
 1 % of base contract  
 \$7 million or more  
 .75 % of base contract

#### **L. Preference for Section 3 Certified Contractors**

1. An award shall be given to the qualified and responsible Section 3 Business Concern with the lowest responsive bid, if that bid is:

a. Within the maximum total contract price established in the contracting budget for the specific project for which bids are being taken, and

b. Not more than "X" higher than the total bid price of the lowest responsive bid from any responsible, responsive bidder.

"X" is determined as follows,

X= the lesser of:

**When the lowest responsive bid is less than \$100,000**

10 % of that bid or \$ 9,000

**At least \$100,000, but less than \$200,000**

9% of that bid, or \$16,000

**At least \$200,000, but less than \$300,000**

8% of that bid, or \$21,000

**At least \$300,000, but less than \$400,000**

7% of that bid, or \$24,000

**At least \$400,000, but less than \$500,000**

6% of that bid, or \$25,000

**At least \$500,000, but less than \$1 million**

5% of that bid, or \$40,000

**At least \$1 million, but less than \$2 million**

4% of that bid, or \$60,000

**At least \$2 million, but less than \$4 million**

3% of that bid, or \$80,000

**At least \$4 million, but less than \$7 million**

2% of that bid, or \$105,000

**\$7 million or more**

1-1/2% of the lowest responsive bid, with no dollar limit if no responsive bid by a Section 3 business concern meets the requirements of section L. of this clause, the contract shall be awarded to a responsive bidder with the lowest responsive bid.

#### **M. Section 3 Business Concern**

Is a business in which:

1. 51 percent of the business, or more, is owned by Section 3 residents; or
2. Is a business that at least 30 percent of its permanent, full time employees include people who are currently Section 3 residents, or within three years of the date of their first employment with the business were Section 3 residents; or
3. A business that provides evidence of a commitment to sub-contract in excess of 25 percent of the dollar award of all sub-contracts to be awarded to business concerns that meet the qualifications set forth in paragraphs 1. or 2.

**N. Fines for Non-Compliance**

Contractors found to have violated the terms of this clause are liable for fines in an amount equal to the amounts paid into the training fund as specified above in section K. The Prince George's County Housing Authority will not consider the contractor responsive for future contracts for a period of 120 days after the fine is paid.

**O. Contractors that are Unable to Engage in Opportunities for Section 3/Business**

For contractors that do not engage in training, employment, and contracting opportunities for Section 3 residents, the contractor must contribute to the Prince George's County Housing Authority training fund. For all contracts awarded to sub-contractors, the prime contractor must ensure that, to the greatest extent feasible, all sub-contractors will provide training, employment, contracting, and joint venture opportunities to Section 3 residents and business concerns of the Prince George's County Housing Authority.

**P. Section 3 Joint Venture**

A Section 3 joint venture is an association of business concerns, one of which qualifies as a Section 3 business concern, formed by a written joint venture agreement to engage in and carry out a specific business venture where the business concerns combine their efforts, resources, skills and knowledge for joint profit, but not necessarily on a continuing or permanent basis and for which the Section 3 business concern is responsible for a clearly defined portion of the work to be performed and:

- i. Holds management responsibilities in the venture, and
- ii. Performs at least 25 percent of the work and
- iii. Is contractually entitled to compensation proportionate to its work.



**FY 2016 Income Limits Summary**

FY 2016 Income Limit Area	Median Income <small>Explanation</small>	FY 2016 Income Limit Category	Persons in Family							
			1	2	3	4	5	6	7	8
Prince George's County	\$108,600	Very Low (50%) Income Limits (\$) <small>Explanation</small>	38,050	43,450	48,900	54,300	58,650	63,000	67,350	71,700
		Extremely Low Income Limits (\$) <sup>a</sup> <small>Explanation</small>	22,850	26,100	29,350	32,600	35,250	37,850	40,450	43,050
		Low (80%) Income Limits (\$) <small>Explanation</small>	49,150	56,150	63,150	70,150	75,800	81,400	87,000	92,600

The Prince George's County income limits for Low-and Very Low-income persons are updated annually by HUD. The additional regarding The Income Limits information indicated here can be found at the following HUD.GOV website: <https://www.huduser.gov/portal/datasets/il/li2016/2016summary.odn>

**NON COLLUSIVE AFFIDAVIT**

STATE OF MARYLAND)

) ss.:

COUNTY OF PRINCE GEORGE'S)

I, \_\_\_\_\_, being duly sworn, depose and say:

That I am the party making the foregoing proposal or bid as an individual or an authorized member of a partnership or corporation, that such proposal is genuine and not collusive or sham, that said bidder along with its officers, partners, owners, agents representatives, employees or parties in interest, have not colluded, conspired, connived or agreed, directly or indirectly with any bidder or person to put in a sham bid or to refrain from bidding, and has not in any manner, directly or indirectly, sought by agreement of collusion, or communication or conference, with any person to fix the bid price of the affiant or of any other bidder, or to fix any overhead, profit or cost element of said bid price or of that of any bidder, or to secure any advantage against the Housing Authority of Prince George's county or any person interested in any proposed contract, and that all statements in said proposal or bid are true.

The price or prices quoted in the attached bid are fair and proper and are not tainted by any collusion, conspiracy, connivance or unlawful agreement on the part of the bidder or any of its representatives, agents, owners, employees, or parties in interest, including this affiant.

\_\_\_\_\_

Signature and Title

SUBSCRIBED AND SWORN TO

before me this \_\_\_\_\_

day of \_\_\_\_\_, 20\_\_\_\_.

\_\_\_\_\_

**CERTIFICATION FOR BUSINESS CONCERNS SEEKING SECTION 3  
PREFERENCE IN CONTRACTING AND DEMONSTRATION OF CAPABILITY**

Name of Business \_\_\_\_\_

Address of Business \_\_\_\_\_

Type of Business:       Corporation               Partnership  
                                  Sole Proprietorship       Joint Venture

Attached is the following documentation as evidence of status:

**For Business claiming status as a Section 3 resident-owned enterprise:**

- Copy of resident lease
- Copy of receipt of public assistance
- Copy of evidence of participation in a public assistance program
- Other evidence

**For business entity as applicable:**

- Copy of Articles of Incorporation
- Certificate of Good Standing
- Assumed Business Name Certificate
- Partnership Agreement
- List of owners/stockholders and % ownership of each
- Corporation Annual Report
- Latest Board minutes appointing officers
- Organization chart with names and titles and brief function statement
- Additional documentation

**For business claiming Section 3 status by subcontracting 25 percent of the dollar awarded to qualified Section 3 business:**

- List of subcontracted Section 3 business(es) and subcontract amount

**For business claiming Section 3 status, claiming at least 30 percent of their workforce are currently Section 3 residents or were Section 3 eligible residents within 3 years of date of first employment with the business:**

- List of all current full-time employees
- List of employees claiming Section 3 status
- PHA/IHA Residential lease less than 3 years from day of employment
- Other evidence of Section 3 status less than 3 years from date of employment

**Evidence of ability to perform successfully under the terms and conditions of the proposed contract:**

- Current financial statement
- Statement of ability to comply with public policy
- List of owned equipment
- List of all contracts for the past two years

\_\_\_\_\_  
Authorizing Name and Signature

(Corporate Seal)

Attested by: \_\_\_\_\_

**U.S. Department of Housing and  
Urban Development**  
Office of Public and Indian Housing

**Instructions to Bidders for Contracts  
Public and Indian Housing Programs**

# Instructions to Bidders for Contracts Public and Indian Housing Programs

## Table of Contents

Clause	Page
1. Bid Preparation and Submission	1
2. Explanations and Interpretations to Prospective Bidders	1
3. Amendments to Invitations for Bids	1
4. Responsibility of Prospective Contractor	1
5. Late Submissions, Modifications, and Withdrawal of Bids	1
6. Bid Opening	2
7. Service of Protest	2
8. Contract Award	2
9. Bid Guarantee	3
10. Assurance of Completion	3
11. Preconstruction Conference	3
12. Indian Preference Requirements	3

### 1. Bid Preparation and Submission

(a) Bidders are expected to examine the specifications, drawings, all instructions, and, if applicable, the construction site (see also the contract clause entitled **Site Investigation and Conditions Affecting the Work of the General Conditions of the Contract for Construction**). Failure to do so will be at the bidders' risk.

(b) All bids must be submitted on the forms provided by the Public Housing Agency/Indian Housing Authority (PHA/IHA). Bidders shall furnish all the information required by the solicitation. Bids must be signed and the bidder's name typed or printed on the bid sheet and each continuation sheet which requires the entry of information by the bidder. Erasures or other changes must be initialed by the person signing the bid. Bids signed by an agent shall be accompanied by evidence of that agent's authority. (Bidders should retain a copy of their bid for their records.)

(c) Bidders must submit as part of their bid a completed form HUD-5369-A, "Representations, Certifications, and Other Statements of Bidders."

(d) All bid documents shall be sealed in an envelope which shall be clearly marked with the words "Bid Documents," the Invitation for Bids (IFB) number, any project or other identifying number, the bidder's name, and the date and time for receipt of bids.

(e) If this solicitation requires bidding on all items, failure to do so will disqualify the bid. If bidding on all items is not required, bidders should insert the words "No Bid" in the space provided for any item on which no price is submitted.

(f) Unless expressly authorized elsewhere in this solicitation, alternate bids will not be considered.

(g) Unless expressly authorized elsewhere in this solicitation, bids submitted by telegraph or facsimile (fax) machines will not be considered.

(h) If the proposed contract is for a Mutual Help project (as described in 24 CFR Part 905, Subpart E) that involves Mutual Help contributions of work, material, or equipment, supplemental information regarding the bid advertisement is provided as an attachment to this solicitation.

### 2. Explanations and Interpretations to Prospective Bidders

(a) Any prospective bidder desiring an explanation or interpretation of the solicitation, specifications, drawings, etc., must request it at least 7 days before the scheduled time for bid opening. Requests may be oral or written. Oral requests must be confirmed in writing. The only oral clarifications that will be provided will be those clearly related to solicitation procedures, i.e., not substantive technical information. No other oral explanation or interpretation will be provided. Any information given a prospective bidder concerning this solicitation will be furnished promptly to all other prospective bidders as a written amendment to the solicitation, if that information is necessary in submitting bids, or if the lack of it would be prejudicial to other prospective bidders.

(b) Any information obtained by, or provided to, a bidder other than by formal amendment to the solicitation shall not constitute a change to the solicitation.

### 3. Amendments to Invitations for Bids

(a) If this solicitation is amended, then all terms and conditions which are not modified remain unchanged.

(b) Bidders shall acknowledge receipt of any amendment to this solicitation (1) by signing and returning the amendment, (2) by identifying the amendment number and date on the bid form, or (3) by letter, telegram, or facsimile, if those methods are authorized in the solicitation. The PHA/IHA must receive acknowledgement by the time and at the place specified for receipt of bids. Bids which fail to acknowledge the bidder's receipt of any amendment will result in the rejection of the bid if the amendment(s) contained information which substantively changed the PHA's/IHA's requirements.

(c) Amendments will be on file in the offices of the PHA/IHA and the Architect at least 7 days before bid opening.

### 4. Responsibility of Prospective Contractor

(a) The PHA/IHA will award contracts only to responsible prospective contractors who have the ability to perform successfully under the terms and conditions of the proposed contract. In determining the responsibility of a bidder, the PHA/IHA will consider such matters as the bidder's:

- (1) Integrity;
- (2) Compliance with public policy;
- (3) Record of past performance; and
- (4) Financial and technical resources (including construction and technical equipment).

(b) Before a bid is considered for award, the bidder may be requested by the PHA/IHA to submit a statement or other documentation regarding any of the items in paragraph (a) above. Failure by the bidder to provide such additional information shall render the bidder nonresponsible and ineligible for award.

## 5. Late Submissions, Modifications, and Withdrawal of Bids

(a) Any bid received at the place designated in the solicitation after the exact time specified for receipt will not be considered unless it is received before award is made and it:

(1) Was sent by registered or certified mail not later than the fifth calendar day before the date specified for receipt of offers (e.g., an offer submitted in response to a solicitation requiring receipt of offers by the 20th of the month must have been mailed by the 15th);

(2) Was sent by mail, or if authorized by the solicitation, was sent by telegram or via facsimile, and it is determined by the PHA/IHA that the late receipt was due solely to mishandling by the PHA/IHA after receipt at the PHA/IHA; or

(3) Was sent by U.S. Postal Service Express Mail Next Day Service - Post Office to Addressee, not later than 5:00 p.m. at the place of mailing two working days prior to the date specified for receipt of proposals. The term "working days" excludes weekends and observed holidays.

(b) Any modification or withdrawal of a bid is subject to the same conditions as in paragraph (a) of this provision.

(c) The only acceptable evidence to establish the date of mailing of a late bid, modification, or withdrawal sent either by registered or certified mail is the U.S. or Canadian Postal Service postmark both on the envelope or wrapper and on the original receipt from the U.S. or Canadian Postal Service. Both postmarks must show a legible date or the bid, modification, or withdrawal shall be processed as if mailed late. "Postmark" means a printed, stamped, or otherwise placed impression (exclusive of a postage meter machine impression) that is readily identifiable without further action as having been supplied and affixed by employees of the U.S. or Canadian Postal Service on the date of mailing. Therefore, bidders should request the postal clerk to place a hand cancellation bull's-eye postmark on both the receipt and the envelope or wrapper.

(d) The only acceptable evidence to establish the time of receipt at the PHA/IHA is the time/date stamp of PHA/IHA on the proposal wrapper or other documentary evidence of receipt maintained by the PHA/IHA.

(e) The only acceptable evidence to establish the date of mailing of a late bid, modification, or withdrawal sent by Express Mail Next Day Service-Post Office to Addressee is the date entered by the post office receiving clerk on the "Express Mail Next Day Service-Post Office to Addressee" label and the postmark on both the envelope or wrapper and on the original receipt from the U.S. Postal Service. "Postmark" has the same meaning as defined in paragraph (c) of this provision, excluding postmarks of the Canadian Postal Service. Therefore, bidders should request the postal clerk to place a legible hand cancellation bull's eye postmark on both the receipt and Failure by a bidder to acknowledge receipt of the envelope or wrapper.

(f) Notwithstanding paragraph (a) of this provision, a late modification of an otherwise successful bid that makes its terms more favorable to the PHA/IHA will be considered at any time it is received and may be accepted.

(g) Bids may be withdrawn by written notice, or if authorized by this solicitation, by telegram (including mailgram) or facsimile machine transmission received at any time before the exact time set for opening of bids; provided that written confirmation of telegraphic or facsimile withdrawals over the signature of the bidder is mailed and postmarked prior to the specified bid opening time. A bid may be withdrawn in person by a bidder or its authorized representative if, before the exact time set for opening of bids, the identity of the person requesting withdrawal is established and the person signs a receipt for the bid.

## 6. Bid Opening

All bids received by the date and time of receipt specified in the solicitation will be publicly opened and read. The time and place of opening will be as specified in the solicitation. Bidders and other interested persons may be present.

## 7. Service of Protest

(a) Definitions. As used in this provision:

"Interested party" means an actual or prospective bidder whose direct economic interest would be affected by the award of the contract.

"Protest" means a written objection by an interested party to this solicitation or to a proposed or actual award of a contract pursuant to this solicitation.

(b) Protests shall be served on the Contracting Officer by obtaining written and dated acknowledgement from —

[Contracting Officer designate the official or location where a protest may be served on the Contracting Officer]

(c) All protests shall be resolved in accordance with the PHA's/IHA's protest policy and procedures, copies of which are maintained at the PHA/IHA.

## 8. Contract Award

(a) The PHA/IHA will evaluate bids in response to this solicitation without discussions and will award a contract to the responsible bidder whose bid, conforming to the solicitation, will be most advantageous to the PHA/IHA considering only price and any price-related factors specified in the solicitation.

(b) If the apparent low bid received in response to this solicitation exceeds the PHA's/IHA's available funding for the proposed contract work, the PHA/IHA may either accept separately priced items (see 8(e) below) or use the following procedure to determine contract award. The PHA/IHA shall apply in turn to each bid (proceeding in order from the apparent low bid to the high bid) each of the separately priced bid deductible items, if any, in their priority order set forth in this solicitation. If upon the application of the first deductible item to all initial bids, a new low bid is within the PHA's/IHA's available funding, then award shall be made to that bidder. If no bid is within the available funding amount, then the PHA/IHA shall apply the second deductible item. The PHA/IHA shall continue this process until an evaluated low bid, if any, is within the PHA's/IHA's available funding. If upon the application of all deductibles, no bid is within the PHA's/IHA's available funding, or if the solicitation does not request separately priced deductibles, the PHA/IHA shall follow its written policy and procedures in making any award under this solicitation.

(c) In the case of tie low bids, award shall be made in accordance with the PHA's/IHA's written policy and procedures.

(d) The PHA/IHA may reject any and all bids, except other than the lowest bid (e.g., the apparent low bid is unreasonably low), and waive informalities or minor irregularities in bids received, in accordance with the PHA's/IHA's written policy and procedures.

(e) Unless precluded elsewhere in the solicitation, the PHA/IHA may accept any item or combination of items bid.

(f) The PHA/IHA may reject any bid as nonresponsive if it is materially unbalanced as to the prices for the various items of work to be performed. A bid is materially unbalanced when it is based on prices significantly less than cost for some work and prices which are significantly overstated for other work.

(g) A written award shall be furnished to the successful bidder within the period for acceptance specified in the bid and shall result in a binding contract without further action by either party.

#### **9. Bid Guarantee (applicable to construction and equipment contracts exceeding \$25,000)**

All bids must be accompanied by a negotiable bid guarantee which shall not be less than five percent (5%) of the amount of the bid. The bid guarantee may be a certified check, bank draft, U.S. Government Bonds at par value, or a bid bond secured by a surety company acceptable to the U.S. Government and authorized to do business in the state where the work is to be performed. In the case where the work under the contract will be performed on an Indian reservation area, the bid guarantee may also be an Irrevocable Letter of Credit (see provision 10, Assurance of Completion, below). Certified checks and bank drafts must be made payable to the order of the PHA/IHA. The bid guarantee shall insure the execution of the contract and the furnishing of a method of assurance of completion by the successful bidder as required by the solicitation. Failure to submit a bid guarantee with the bid shall result in the rejection of the bid. Bid guarantees submitted by unsuccessful bidders will be returned as soon as practicable after bid opening.

#### **10. Assurance of Completion**

Unless otherwise provided in State law, the successful bidder shall furnish an assurance of completion prior to the execution of any contract under this solicitation. This assurance may be [Contracting Officer check applicable items] —

[ ] (1) a performance and payment bond in a penal sum of 100 percent of the contract price; or, as may be required or permitted by State law;

[ ] (2) separate performance and payment bonds, each for 50 percent or more of the contract price;

[ ] (3) a 20 percent cash escrow;

[ ] (4) a 25 percent irrevocable letter of credit; or,

[ ] (5) an Irrevocable letter of credit for 10 percent of the total contract price with a monitoring and disbursements agreement with the IHA (applicable only to contracts awarded by an IHA under the Indian Housing Program).

(b) Bonds must be obtained from guarantee or surety companies acceptable to the U.S. Government and authorized to do business in the state where the work is to be performed. Individual sureties will not be considered. U.S. Treasury Circular Number 570, published annually in the Federal Register, lists companies approved to act as sureties on bonds securing Government contracts, the maximum underwriting limits on each contract bonded, and the States in which the company is licensed to do business. Use of companies listed in this circular is mandatory. Copies of the circular may be downloaded on the U.S. Department of Treasury website <http://www.fms.treas.gov/c570/index.html>, or ordered for a minimum fee by contacting the Government Printing Office at (202) 512-2168.

(c) Each bond shall clearly state the rate of premium and the total amount of premium charged. The current power of attorney for the person who signs for the surety company must be attached to the bond. The effective date of the power of attorney shall not precede the date of the bond. The effective date of the bond shall be on or after the execution date of the contract.

(d) Failure by the successful bidder to obtain the required assurance of completion within the time specified, or within such extended period as the PHA/IHA may grant based upon reasons determined adequate by the PHA/IHA, shall render the bidder ineligible for award. The PHA/IHA may then either award the contract to the next lowest responsible bidder or solicit new bids. The PHA/IHA may retain the ineligible bidder's bid guarantee.

#### **11. Preconstruction Conference (applicable to construction contracts)**

After award of a contract under this solicitation and prior to the start of work, the successful bidder will be required to attend a preconstruction conference with representatives of the PHA/IHA and its architect/engineer, and other interested parties convened by the PHA/IHA. The conference will serve to acquaint the participants with the general plan of the construction operation and all other requirements of the contract (e.g., Equal Employment Opportunity, Labor Standards). The PHA/IHA will provide the successful bidder with the date, time, and place of the conference.

#### **12. Indian Preference Requirements (applicable only if this solicitation is for a contract to be performed on a project for an Indian Housing Authority)**

(a) HUD has determined that the contract awarded under this solicitation is subject to the requirements of section 7(b) of the Indian Self-Determination and Education Assistance Act (25 U.S.C. 450e(b)). Section 7(b) requires that any contract or subcontract entered into for the benefit of Indians shall require that, to the greatest extent feasible

(1) Preferences and opportunities for training and employment (other than core crew positions; see paragraph (h) below) in connection with the administration of such contracts or subcontracts be given to qualified "Indians." The Act defines "Indians" to mean persons who are members of an Indian tribe and defines "Indian tribe" to mean any Indian tribe, band, nation, or other organized group or community, including any Alaska Native village or regional or village corporation as defined in or established pursuant to the Alaska Native Claims Settlement Act, which is recognized as eligible for the special programs and services provided by the United States to Indians because of their status as Indians; and,

(2) Preference in the award of contracts or subcontracts in connection with the administration of contracts be given to Indian organizations and to Indian-owned economic enterprises, as defined in section 3 of the Indian Financing Act of 1974 (25 U.S.C. 1452). That Act defines "economic enterprise" to mean any Indian-owned commercial, industrial, or business activity established or organized for the purpose of profit, except that the Indian ownership must constitute not less than 51 percent of the enterprise; "Indian organization" to mean the governing body of any Indian tribe or entity established or recognized by such governing body; "Indian" to mean any person who is a member of any tribe, band, group, pueblo, or community which is recognized by the Federal Government as eligible for services from the Bureau of Indian Affairs and any "Native" as defined in the Alaska Native Claims Settlement Act; and Indian "tribe" to mean any Indian tribe, band, group, pueblo, or community including Native villages and Native groups (including

corporations organized by Kenai, Juneau, Sitka, and Kodiak) as defined in the Alaska Native Claims Settlement Act, which is recognized by the Federal Government as eligible for services from the Bureau of Indian Affairs.

(b) (1) The successful Contractor under this solicitation shall comply with the requirements of this provision in awarding all subcontracts under the contract and in providing training and employment opportunities.

(2) A finding by the IHA that the contractor, either (i) awarded a subcontract without using the procedure required by the IHA, (ii) falsely represented that subcontracts would be awarded to Indian enterprises or organizations; or, (iii) failed to comply with the contractor's employment and training preference bid statement shall be grounds for termination of the contract or for the assessment of penalties or other remedies.

(c) If specified elsewhere in this solicitation, the IHA may restrict the solicitation to qualified Indian-owned enterprises and Indian organizations. If two or more (or a greater number as specified elsewhere in the solicitation) qualified Indian-owned enterprises or organizations submit responsive bids, award shall be made to the qualified enterprise or organization with the lowest responsive bid. If fewer than the minimum required number of qualified Indian-owned enterprises or organizations submit responsive bids, the IHA shall reject all bids and readvertise the solicitation in accordance with paragraph (d) below.

(d) If the IHA prefers not to restrict the solicitation as described in paragraph (c) above, or if after having restricted a solicitation an insufficient number of qualified Indian enterprises or organizations submit bids, the IHA may advertise for bids from non-Indian as well as Indian-owned enterprises and Indian organizations. Award shall be made to the qualified Indian enterprise or organization with the lowest responsive bid if that bid is -

(1) Within the maximum HUD-approved budget amount established for the specific project or activity for which bids are being solicited; and

(2) No more than the percentage specified in 24 CFR 905.175(c) higher than the total bid price of the lowest responsive bid from any qualified bidder. If no responsive bid by a qualified Indian-owned economic enterprise or organization is within the stated range of the total bid price of the lowest responsive bid from any qualified enterprise, award shall be made to the bidder with the lowest bid.

(e) Bidders seeking to qualify for preference in contracting or subcontracting shall submit proof of Indian ownership with their bids. Proof of Indian ownership shall include but not be limited to:

(1) Certification by a tribe or other evidence that the bidder is an Indian. The IHA shall accept the certification of a tribe that an individual is a member.

(2) Evidence such as stock ownership, structure, management, control, financing and salary or profit sharing arrangements of the enterprise.

(f) (1) All bidders must submit with their bids a statement describing how they will provide Indian preference in the award of subcontracts. The specific requirements of that statement and the factors to be used by the IHA in determining the statement's adequacy are included as an attachment to this solicitation. Any bid that fails to include the required statement shall be rejected as nonresponsive. The IHA may require that comparable statements be provided by subcontractors to the successful Contractor, and may require the Contractor to reject any bid or proposal by a subcontractor that fails to include the statement.

(2) Bidders and prospective subcontractors shall submit a certification (supported by credible evidence) to the IHA in any instance where the bidder or subcontractor believes it is infeasible to provide Indian preference in subcontracting. The acceptance or rejection by the IHA of the certification shall be final. Rejection shall disqualify the bid from further consideration.

(g) All bidders must submit with their bids a statement detailing their employment and training opportunities and their plans to provide preference to Indians in implementing the contract; and the number or percentage of Indians anticipated to be employed and trained. Comparable statements from all proposed subcontractors must be submitted. The criteria to be used by the IHA in determining the statement(s)'s adequacy are included as an attachment to this solicitation. Any bid that fails to include the required statement(s), or that includes a statement that does not meet minimum standards required by the IHA shall be rejected as nonresponsive.

(h) Core crew employees. A core crew employee is an individual who is a bona fide employee of the contractor at the time the bid is submitted; or an individual who was not employed by the bidder at the time the bid was submitted, but who is regularly employed by the bidder in a supervisory or other key skilled position when work is available. Bidders shall submit with their bids a list of all core crew employees.

(i) Preference in contracting, subcontracting, employment, and training shall apply not only on-site, on the reservation, or within the IHA's jurisdiction, but also to contracts with firms that operate outside these areas (e.g., employment in modular or manufactured housing construction facilities).

(j) Bidders should contact the IHA to determine if any additional local preference requirements are applicable to this solicitation.

(k) The IHA [ ] does [ ] does not [Contracting Officer check applicable box] maintain lists of Indian-owned economic enterprises and Indian organizations by specialty (e.g., plumbing, electrical, foundations), which are available to bidders to assist them in meeting their responsibility to provide preference in connection with the administration of contracts and subcontracts.

**U.S. Department of Housing  
and Urban Development**  
Office of Public and Indian Housing

**Representations, Certifications,  
and Other Statements of Bidders**  
**Public and Indian Housing Programs**

# Representations, Certifications, and Other Statements of Bidders Public and Indian Housing Programs

## Table of Contents

Clause	Page
1. Certificate of Independent Price Determination	1
2. Contingent Fee Representation and Agreement	1
3. Certification and Disclosure Regarding Payments to Influence Certain Federal Transactions	1
4. Organizational Conflicts of Interest Certification	2
5. Bidder's Certification of Eligibility	2
6. Minimum Bid Acceptance Period	2
7. Small, Minority, Women-Owned Business Concern Representation	2
8. Indian-Owned Economic Enterprise and Indian Organization Representation	2
9. Certification of Eligibility Under the Davis-Bacon Act	3
10. Certification of Nonsegregated Facilities	3
11. Clean Air and Water Certification	3
12. Previous Participation Certificate	3
13. Bidder's Signature	3

### 1. Certificate of Independent Price Determination

#### (a) The bidder certifies that--

(1) The prices in this bid have been arrived at independently, without, for the purpose of restricting competition, any consultation, communication, or agreement with any other bidder or competitor relating to (i) those prices, (ii) the intention to submit a bid, or (iii) the methods or factors used to calculate the prices offered;

(2) The prices in this bid have not been and will not be knowingly disclosed by the bidder, directly or indirectly, to any other bidder or competitor before bid opening (in the case of a sealed bid solicitation) or contract award (in the case of a competitive proposal solicitation) unless otherwise required by law; and

(3) No attempt has been made or will be made by the bidder to induce any other concern to submit or not to submit a bid for the purpose of restricting competition.

#### (b) Each signature on the bid is considered to be a certification by the signatory that the signatory--

(1) Is the person in the bidder's organization responsible for determining the prices being offered in this bid or proposal, and that the signatory has not participated and will not participate in any action contrary to subparagraphs (a)(1) through (a)(3) above; or

(2) (i) Has been authorized, in writing, to act as agent for the following principals in certifying that those principals have not participated, and will not participate in any action contrary to subparagraphs (a)(1) through (a)(3) above.

[Insert full name of person(s) in the bidder's organization responsible for determining the prices offered in this bid or proposal, and the title of his or her position in the bidder's organization];

(ii) As an authorized agent, does certify that the principals named in subdivision (b)(2)(i) above have not participated, and will not participate, in any action contrary to subparagraphs (a)(1) through (a)(3) above; and

(iii) As an agent, has not personally participated, and will not participate in any action contrary to subparagraphs (a)(1) through (a)(3) above.

(c) If the bidder deletes or modifies subparagraph (a)2 above, the bidder must furnish with its bid a signed statement setting forth in detail the circumstances of the disclosure.

[ ] [Contracting Officer check if following paragraph is applicable]

(d) Non-collusive affidavit. (applicable to contracts for construction and equipment exceeding \$50,000)

(1) Each bidder shall execute, in the form provided by the PHA/IHA, an affidavit to the effect that he/she has not colluded with any other person, firm or corporation in regard to any bid submitted in response to this solicitation. If the successful bidder did not submit the affidavit with his/her bid, he/she must submit it within three (3) working days of bid opening. Failure to submit the affidavit by that date may render the bid nonresponsive. No contract award will be made without a properly executed affidavit.

(2) A fully executed "Non-collusive Affidavit" [ ] is, [ ] is not included with the bid.

### 2. Contingent Fee Representation and Agreement

#### (a) Definitions. As used in this provision:

"Bona fide employee" means a person, employed by a bidder and subject to the bidder's supervision and control as to time, place, and manner of performance, who neither exerts, nor proposes to exert improper influence to solicit or obtain contracts nor holds out as being able to obtain any contract(s) through improper influence.

"Improper influence" means any influence that induces or tends to induce a PHA/IHA employee or officer to give consideration or to act regarding a PHA/IHA contract on any basis other than the merits of the matter.

(b) The bidder represents and certifies as part of its bid that, except for full-time bona fide employees working solely for the bidder, the bidder:

(1) [ ] has, [ ] has not employed or retained any person or company to solicit or obtain this contract; and

(2) [ ] has, [ ] has not paid or agreed to pay to any person or company employed or retained to solicit or obtain this contract any commission, percentage, brokerage, or other fee contingent upon or resulting from the award of this contract.

(c) If the answer to either (a)(1) or (a)(2) above is affirmative, the bidder shall make an immediate and full written disclosure to the PHA/IHA Contracting Officer.

(d) Any misrepresentation by the bidder shall give the PHA/IHA the right to (1) terminate the contract; (2) at its discretion, deduct from contract payments the amount of any commission, percentage, brokerage, or other contingent fee; or (3) take other remedy pursuant to the contract.

### 3. Certification and Disclosure Regarding Payments to Influence Certain Federal Transactions (applicable to contracts exceeding \$100,000)

(a) The definitions and prohibitions contained in Section 1352 title 31, United States Code, are hereby incorporated by reference in paragraph (b) of this certification.

(b) The bidder, by signing its bid, hereby certifies to the best of his or her knowledge and belief as of December 23, 1989 that:

(1) No Federal appropriated funds have been paid or will be paid to any person for influencing or attempting to influence an officer or employee of any agency, a Member of Congress, an officer or employee of Congress, or an employee of a Member of Congress on his or her behalf in connection with the awarding of a contract resulting from this solicitation;

(2) If any funds other than Federal appropriated funds (including profit or fee received under a covered Federal transaction) have been paid, or will be paid, to any person for influencing or attempting to influence an officer or employee of any agency, a Member of Congress, an officer or employee of Congress, or an employee of a Member of Congress on his or her behalf in connection with this solicitation, the bidder shall complete and submit, with its bid, OMB standard form LLL, "Disclosure of Lobbying Activities;" and

(3) He or she will include the language of this certification in all subcontracts at any tier and require that all recipients of subcontract awards in excess of \$100,000 shall certify and disclose accordingly.

(c) Submission of this certification and disclosure is a prerequisite for making or entering into this contract imposed by section 1352, title 31, United States Code. Any person who makes an expenditure prohibited under this provision or who fails to file or amend the disclosure form to be filed or amended by this provision, shall be subject to a civil penalty of not less than \$10,000, and not more than \$100,000, for each such failure.

(d) Indian tribes (except those chartered by States) and Indian organizations as defined in section 4 of the Indian Self-Determination and Education Assistance Act (25 U.S.C. 450B) are exempt from the requirements of this provision.

#### 4. Organizational Conflicts of Interest Certification

The bidder certifies that to the best of its knowledge and belief and except as otherwise disclosed, he or she does not have any organizational conflict of interest which is defined as a situation in which the nature of work to be performed under this proposed contract and the bidder's organizational, financial, contractual, or other interests may, without some restriction on future activities:

- (a) Result in an unfair competitive advantage to the bidder; or,
  - (b) Impair the bidder's objectivity in performing the contract work.
- [ ] In the absence of any actual or apparent conflict, I hereby certify that to the best of my knowledge and belief, no actual or apparent conflict of interest exists with regard to my possible performance of this procurement.

#### 5. Bidder's Certification of Eligibility

(a) By the submission of this bid, the bidder certifies that to the best of its knowledge and belief, neither it, nor any person or firm which has an interest in the bidder's firm, nor any of the bidder's subcontractors, is ineligible to:

(1) Be awarded contracts by any agency of the United States Government, HUD, or the State in which this contract is to be performed; or,

(2) Participate in HUD programs pursuant to 24 CFR Part 24.

(b) The certification in paragraph (a) above is a material representation of fact upon which reliance was placed when making award. If it is later determined that the bidder knowingly rendered an erroneous certification, the contract may be terminated for default, and the bidder may be debarred or suspended from participation in HUD programs and other Federal contract programs.

#### 6. Minimum Bid Acceptance Period

(a) "Acceptance period," as used in this provision, means the number of calendar days available to the PHA/IHA for awarding a contract from the date specified in this solicitation for receipt of bids.

(b) This provision supersedes any language pertaining to the acceptance period that may appear elsewhere in this solicitation.

(c) The PHA/IHA requires a minimum acceptance period of [Contracting Officer insert time period] calendar days.

(d) In the space provided immediately below, bidders may specify a longer acceptance period than the PHA's/IHA's minimum requirement. The bidder allows the following acceptance period: calendar days.

(e) A bid allowing less than the PHA's/IHA's minimum acceptance period will be rejected.

(f) The bidder agrees to execute all that it has undertaken to do, in compliance with its bid, if that bid is accepted in writing within (1) the acceptance period stated in paragraph (c) above or (2) any longer acceptance period stated in paragraph (d) above.

#### 7. Small, Minority, Women-Owned Business Concern Representation

The bidder represents and certifies as part of its bid/ offer that it -

(a) [ ] is, [ ] is not a small business concern. "Small business concern," as used in this provision, means a concern, including its affiliates, that is independently owned and operated, not dominant in the field of operation in which it is bidding, and qualified as a small business under the criteria and size standards in 13 CFR 121.

(b) [ ] is, [ ] is not a women-owned business enterprise. "Women-owned business enterprise," as used in this provision, means a business that is at least 51 percent owned by a woman or women who are U.S. citizens and who also control and operate the business.

(c) [ ] is, [ ] is not a minority business enterprise. "Minority business enterprise," as used in this provision, means a business which is at least 51 percent owned or controlled by one or more minority group members or, in the case of a publicly owned business, at least 51 percent of its voting stock is owned by one or more minority group members, and whose management and daily operations are controlled by one or more such individuals. For the purpose of this definition, minority group members are:

(Check the block applicable to you)

- |                        |                              |
|------------------------|------------------------------|
| [ ] Black Americans    | [ ] Asian Pacific Americans  |
| [ ] Hispanic Americans | [ ] Asian Indian Americans   |
| [ ] Native Americans   | [ ] Hasidic Jewish Americans |

#### 8. Indian-Owned Economic Enterprise and Indian Organization Representation (applicable only if this solicitation is for a contract to be performed on a project for an Indian Housing Authority)

The bidder represents and certifies that it:

(a) [ ] is, [ ] is not an Indian-owned economic enterprise. "Economic enterprise," as used in this provision, means any commercial, industrial, or business activity established or organized for the purpose of profit, which is at least 51 percent Indian owned. "Indian," as used in this provision, means any person who is a member of any tribe, band, group, pueblo, or community which is recognized by the Federal Government as eligible for services from the Bureau of Indian Affairs and any "Native" as defined in the Alaska Native Claims Settlement Act.

(b) [ ] is, [ ] is not an Indian organization. "Indian organization," as used in this provision, means the governing body of any Indian tribe or entity established or recognized by such governing body. Indian "tribe" means any Indian tribe, band, group, pueblo, or

community including Native villages and Native groups (including corporations organized by Kenai, Juneau, Sitka, and Kodiak) as defined in the Alaska Native Claims Settlement Act, which is recognized by the Federal Government as eligible for services from the Bureau of Indian Affairs.

**9. Certification of Eligibility Under the Davis-Bacon Act** (applicable to construction contracts exceeding \$2,000)

(a) By the submission of this bid, the bidder certifies that neither it nor any person or firm who has an interest in the bidder's firm is a person or firm ineligible to be awarded contracts by the United States Government by virtue of section 3(a) of the Davis-Bacon Act or 29 CFR 5.12(a)(1).

(b) No part of the contract resulting from this solicitation shall be subcontracted to any person or firm ineligible to be awarded contracts by the United States Government by virtue of section 3(a) of the Davis-Bacon Act or 29 CFR 5.12(a)(1).

(c) The penalty for making false statements is prescribed in the U. S. Criminal Code, 18 U.S.C. 1001.

**10. Certification of Nonsegregated Facilities** (applicable to contracts exceeding \$10,000)

(a) The bidder's attention is called to the clause entitled **Equal Employment Opportunity** of the General Conditions of the Contract for Construction.

(b) "Segregated facilities," as used in this provision, means any waiting rooms, work areas, rest rooms and wash rooms, restaurants and other eating areas, time clocks, locker rooms and other storage or dressing areas, parking lots, drinking fountains, recreation or entertainment areas, transportation, and housing facilities provided for employees, that are segregated by explicit directive or are in fact segregated on the basis of race, color, religion, or national origin because of habit, local custom, or otherwise.

(c) By the submission of this bid, the bidder certifies that it does not and will not maintain or provide for its employees any segregated facilities at any of its establishments, and that it does not and will not permit its employees to perform their services at any location under its control where segregated facilities are maintained. The bidder agrees that a breach of this certification is a violation of the Equal Employment Opportunity clause in the contract.

(d) The bidder further agrees that (except where it has obtained identical certifications from proposed subcontractors for specific time periods) prior to entering into subcontracts which exceed \$10,000 and are not exempt from the requirements of the Equal Employment Opportunity clause, it will:

- (1) Obtain identical certifications from the proposed subcontractors;
- (2) Retain the certifications in its files; and
- (3) Forward the following notice to the proposed subcontractors (except if the proposed subcontractors have submitted identical certifications for specific time periods):

**Notice to Prospective Subcontractors of Requirement for Certifications of Nonsegregated Facilities**

A Certification of Nonsegregated Facilities must be submitted before the award of a subcontract exceeding \$10,000 which is not exempt from the provisions of the Equal Employment Opportunity clause of the prime contract. The certification may be submitted either for each subcontract or for all subcontracts during a period (i.e., quarterly, semiannually, or annually).

**Note:** The penalty for making false statements in bids is prescribed in 18 U.S.C. 1001.

**11. Clean Air and Water Certification** (applicable to contracts exceeding \$100,000)

The bidder certifies that:

(a) Any facility to be used in the performance of this contract [ ] is, [ ] is not listed on the Environmental Protection Agency List of Violating Facilities:

(b) The bidder will immediately notify the PHA/IHA Contracting Officer, before award, of the receipt of any communication from the Administrator, or a designee, of the Environmental Protection Agency, indicating that any facility that the bidder proposes to use for the performance of the contract is under consideration to be listed on the EPA List of Violating Facilities; and,

(c) The bidder will include a certification substantially the same as this certification, including this paragraph (c), in every nonexempt subcontract.

**12. Previous Participation Certificate** (applicable to construction and equipment contracts exceeding \$50,000)

(a) The bidder shall complete and submit with his/her bid the Form HUD-2530, "Previous Participation Certificate." If the successful bidder does not submit the certificate with his/her bid, he/she must submit it within three (3) working days of bid opening. Failure to submit the certificate by that date may render the bid nonresponsive. No contract award will be made without a properly executed certificate.

(b) A fully executed "Previous Participation Certificate" [ ] is, [ ] is not included with the bid.

**13. Bidder's Signature**

The bidder hereby certifies that the information contained in these certifications and representations is accurate, complete, and current.

\_\_\_\_\_  
(Signature and Date)

\_\_\_\_\_  
(Typed or Printed Name)

\_\_\_\_\_  
(Title)

\_\_\_\_\_  
(Company Name)

\_\_\_\_\_  
(Company Address)

# General Conditions for Construction Contracts - Public Housing Programs

U.S. Department of Housing and Urban Development  
Office of Public and Indian Housing  
OMB Approval No. 2577-0157 (exp. 01/31/2014)

**Applicability. This form is applicable to any construction/development contract greater than \$100,000.**

This form includes those clauses required by OMB's common rule on grantee procurement, implemented at HUD in 24 CFR 85.36, and those requirements set forth in Section 3 of the Housing and Urban Development Act of 1968 and its amendment by the Housing and Community Development Act of 1992, implemented by HUD at 24 CFR Part 135. The form is required for construction contracts awarded by Public Housing Agencies (PHAs).

The form is used by Housing Authorities in solicitations to provide necessary contract clauses. If the form were not used, HAs would be unable to enforce their contracts.

Public reporting burden for this collection of information is estimated to average 1.0 hours per response, including the time for reviewing instructions, searching existing data sources, gathering and maintaining the data needed, and completing and reviewing the collection of information. Responses to the collection of information are required to obtain a benefit or to retain a benefit.

The information requested does not lend itself to confidentiality.

HUD may not conduct or sponsor, and a person is not required to respond to a collection of information unless it displays a currently valid OMB number.

## Table of Contents

Clause		Page	Clause		Page
1.	Definitions	2		<b>Administrative Requirements</b>	
2.	Contractor's Responsibility for Work	2	25.	Contract Period	9
3.	Architect's Duties, Responsibilities and Authority	2	26.	Order of Precedence	9
4.	Other Contracts	3	27.	Payments	9
	<b>Construction Requirements</b>		28.	Contract Modifications	10
5.	Preconstruction Conference and Notice to Proceed	3	29.	Changes	10
6.	Construction Progress Schedule	3	30.	Suspension of Work	11
7.	Site Investigation and Conditions Affecting the Work	3	31.	Disputes	11
8.	Differing Site Conditions	4	32.	Default	11
9.	Specifications and Drawings for Construction	4	33.	Liquidated Damages	12
10.	As-Built Drawings	5	34.	Termination of Convenience	12
11.	Material and Workmanship	5	35.	Assignment of Contract	12
12.	Permits and Codes	5	36.	Insurance	12
13.	Health, Safety, and Accident Prevention	6	37.	Subcontracts	13
14.	Temporary Buildings and Transportation Materials	6	38.	Subcontracting with Small and Minority Firms, Women's Business Enterprise, and Labor Surplus Area Firms	13
15.	Availability and Use of Utility Services	6	39.	Equal Employment Opportunity	13
16.	Protection of Existing Vegetation, Structures, Equipment, Utilities, and Improvements	6	40.	Employment, Training, and Contracting Opportunities for Low-Income Persons, Section 3 of the Housing and Urban Development Act of 1968	14
17.	Temporary Buildings and Transportation Materials	7	41.	Interest of Members of Congress	15
18.	Clean Air and Water	7	42.	Interest of Members, Officers, or Employees and Former Members, Officers, or Employees	15
19.	Energy Efficiency	7	43.	Limitations on Payments Made to Influence	15
20.	Inspection and Acceptance of Construction	7	44.	Royalties and Patents	15
21.	Use and Possession Prior to Completion	8	45.	Examination and Retention of Contractor's Records	15
22.	Warranty of Title	8	46.	Labor Standards-Davis-Bacon and Related Acts	15
23.	Warranty of Construction	8	47.	Non-Federal Prevailing Wage Rates	19
24.	Prohibition Against Liens	9	48.	Procurement of Recovered Materials	19

## 1. Definitions

- (a) "Architect" means the person or other entity engaged by the PHA to perform architectural, engineering, design, and other services related to the work as provided for in the contract. When a PHA uses an engineer to act in this capacity, the terms "architect" and "engineer" shall be synonymous. The Architect shall serve as a technical representative of the Contracting Officer. The Architect's authority is as set forth elsewhere in this contract.
- (b) "Contract" means the contract entered into between the PHA and the Contractor. It includes the forms of Bid, the Bid Bond, the Performance and Payment Bond or Bonds or other assurance of completion, the Certifications, Representations, and Other Statements of Bidders (form HUD-5370), these General Conditions of the Contract for Construction (form HUD-5370), the applicable wage rate determinations from the U.S. Department of Labor, any special conditions included elsewhere in the contract, the specifications, and drawings. It includes all formal changes to any of those documents by addendum, change order, or other modification.
- (c) "Contracting Officer" means the person delegated the authority by the PHA to enter into, administer, and/or terminate this contract and designated as such in writing to the Contractor. The term includes any successor Contracting Officer and any duly authorized representative of the Contracting Officer also designated in writing. The Contracting Officer shall be deemed the authorized agent of the PHA in all dealings with the Contractor.
- (d) "Contractor" means the person or other entity entering into the contract with the PHA to perform all of the work required under the contract.
- (e) "Drawings" means the drawings enumerated in the schedule of drawings contained in the Specifications and as described in the contract clause entitled Specifications and Drawings for Construction herein.
- (f) "HUD" means the United States of America acting through the Department of Housing and Urban Development including the Secretary, or any other person designated to act on its behalf. HUD has agreed, subject to the provisions of an Annual Contributions Contract (ACC), to provide financial assistance to the PHA, which includes assistance in financing the work to be performed under this contract. As defined elsewhere in these General Conditions or the contract documents, the determination of HUD may be required to authorize changes in the work or for release of funds to the PHA for payment to the Contractor. Notwithstanding HUD's role, nothing in this contract shall be construed to create any contractual relationship between the Contractor and HUD.
- (g) "Project" means the entire project, whether construction or rehabilitation, the work for which is provided for in whole or in part under this contract.
- (h) "PHA" means the Public Housing Agency organized under applicable state laws which is a party to this contract.
- (i) "Specifications" means the written description of the technical requirements for construction and includes the criteria and tests for determining whether the requirements are met.
- (l) "Work" means materials, workmanship, and manufacture and fabrication of components.

## 2. Contractor's Responsibility for Work

- (a) The Contractor shall furnish all necessary labor, materials, tools, equipment, and transportation necessary for performance of the work. The Contractor shall also furnish all necessary water, heat, light, and power not made available to the Contractor by the PHA pursuant to the clause entitled Availability and Use of Utility Services herein.
- (b) The Contractor shall perform on the site, and with its own organization, work equivalent to at least [ ] (12 percent unless otherwise indicated) of the total amount of work to be performed under the order. This percentage may be reduced by a supplemental agreement to this order if, during performing the work, the Contractor requests a reduction and the Contracting Officer determines that the reduction would be to the advantage of the PHA.
- (c) At all times during performance of this contract and until the work is completed and accepted, the Contractor shall directly superintend the work or assign and have on the work site a competent superintendent who is satisfactory to the Contracting Officer and has authority to act for the Contractor.
- (d) The Contractor shall be responsible for all damages to persons or property that occur as a result of the Contractor's fault or negligence, and shall take proper safety and health precautions to protect the work, the workers, the public, and the property of others. The Contractor shall hold and save the PHA, its officers and agents, free and harmless from liability of any nature occasioned by the Contractor's performance. The Contractor shall also be responsible for all materials delivered and work performed until completion and acceptance of the entire work, except for any completed unit of work which may have been accepted under the contract.
- (e) The Contractor shall lay out the work from base lines and bench marks indicated on the drawings and be responsible for all lines, levels, and measurements of all work executed under the contract. The Contractor shall verify the figures before laying out the work and will be held responsible for any error resulting from its failure to do so.
- (f) The Contractor shall confine all operations (including storage of materials) on PHA premises to areas authorized or approved by the Contracting Officer.
- (g) The Contractor shall at all times keep the work area, including storage areas, free from accumulations of waste materials. After completing the work and before final inspection, the Contractor shall (1) remove from the premises all scaffolding, equipment, tools, and materials (including rejected materials) that are not the property of the PHA and all rubbish caused by its work; (2) leave the work area in a clean, neat, and orderly condition satisfactory to the Contracting Officer; (3) perform all specified tests; and, (4) deliver the installation in complete and operating condition.
- (h) The Contractor's responsibility will terminate when all work has been completed, the final inspection made, and the work accepted by the Contracting Officer. The Contractor will then be released from further obligation except as required by the warranties specified elsewhere in the contract.

## 3. Architect's Duties, Responsibilities, and Authority

- (a) The Architect for this contract, and any successor, shall be designated in writing by the Contracting Officer.

(b) The Architect shall serve as the Contracting Officer's technical representative with respect to architectural, engineering, and design matters related to the work performed under the contract. The Architect may provide direction on contract performance. Such direction shall be within the scope of the contract and may not be of a nature which: (1) institutes additional work outside the scope of the contract; (2) constitutes a change as defined in the Changes clause herein; (3) causes an increase or decrease in the cost of the contract; (4) alters the Construction Progress Schedule; or (5) changes any of the other express terms or conditions of the contract.

(c) The Architect's duties and responsibilities may include but shall not be limited to:

- (1) Making periodic visits to the work site, and on the basis of his/her on-site inspections, issuing written reports to the PHA which shall include all observed deficiencies. The Architect shall file a copy of the report with the Contractor's designated representative at the site;
- (2) Making modifications in drawings and technical specifications and assisting the Contracting Officer in the preparation of change orders and other contract modifications for issuance by the Contracting Officer;
- (3) Reviewing and making recommendations with respect to - (i) the Contractor's construction progress schedules; (ii) the Contractor's shop and detailed drawings; (iii) the machinery, mechanical and other equipment and materials or other articles proposed for use by the Contractor; and, (iv) the Contractor's price breakdown and progress payment estimates; and,
- (4) Assisting in inspections, signing Certificates of Completion, and making recommendations with respect to acceptance of work completed under the contract.

#### 4. Other Contracts

The PHA may undertake or award other contracts for additional work at or near the site of the work under this contract. The Contractor shall fully cooperate with the other contractors and with PHA employees and shall carefully adapt scheduling and performing the work under this contract to accommodate the additional work, heeding any direction that may be provided by the Contracting Officer. The Contractor shall not commit or permit any act that will interfere with the performance of work by any other contractor or by PHA employees

### Construction Requirements

#### 5. Pre-construction Conference and Notice to Proceed

(a) Within ten calendar days of contract execution, and prior to the commencement of work, the Contractor shall attend a preconstruction conference with representatives of the PHA, its Architect, and other interested parties convened by the PHA. The conference will serve to acquaint the participants with the general plan of the construction operation and all other requirements of the contract. The PHA will provide the Contractor with the date, time, and place of the conference.

(b) The contractor shall begin work upon receipt of a written Notice to Proceed from the Contracting Officer or designee. The Contractor shall not begin work prior to receiving such notice.

#### 6. Construction Progress Schedule

(a) The Contractor shall, within five days after the work commences on the contract or another period of time determined by the Contracting Officer, prepare and submit to the Contracting Officer for approval three copies of a practicable schedule showing the order in which the Contractor proposes to perform the work, and the dates on which the Contractor contemplates starting and completing the several salient features of the work (including acquiring labor, materials, and equipment). The schedule shall be in the form of a progress chart of suitable scale to indicate appropriately the percentage of work scheduled for completion by any given date during the period. If the Contractor fails to submit a schedule within the time prescribed, the Contracting Officer may withhold approval of progress payments or take other remedies under the contract until the Contractor submits the required schedule.

(b) The Contractor shall enter the actual progress on the chart as required by the Contracting Officer, and immediately deliver three copies of the annotated schedule to the Contracting Officer. If the Contracting Officer determines, upon the basis of inspection conducted pursuant to the clause entitled Inspection and Acceptance of Construction, herein that the Contractor is not meeting the approved schedule, the Contractor shall take steps necessary to improve its progress, including those that may be required by the Contracting Officer, without additional cost to the PHA. In this circumstance, the Contracting Officer may require the Contractor to increase the number of shifts, overtime operations, days of work, and/or the amount of construction plant, and to submit for approval any supplementary schedule or schedules in chart form as the Contracting Officer deems necessary to demonstrate how the approved rate of progress will be regained.

(c) Failure of the Contractor to comply with the requirements of the Contracting Officer under this clause shall be grounds for a determination by the Contracting Officer that the Contractor is not prosecuting the work with sufficient diligence to ensure completion within the time specified in the Contract. Upon making this determination, the Contracting Officer may terminate the Contractor's right to proceed with the work, or any separable part of it, in accordance with the Default clause of this contract.

#### 7. Site Investigation and Conditions Affecting the Work

(a) The Contractor acknowledges that it has taken steps reasonably necessary to ascertain the nature and location of the work, and that it has investigated and satisfied itself as to the general and local conditions which can affect the work or its cost, including but not limited to, (1) conditions bearing upon transportation, disposal, handling, and storage of materials; (2) the availability of labor, water, electric power, and roads; (3) uncertainties of weather, river stages, tides, or similar physical conditions at the site; (4) the conformation and conditions of the ground; and (5) the character of equipment and facilities needed preliminary to and during work performance. The Contractor also acknowledges that it has satisfied itself as to the character, quality, and quantity of surface and subsurface materials or obstacles to be encountered insofar as this information is

reasonably ascertainable from an inspection of the site, including all exploratory work done by the PHA, as well as from the drawings and specifications made a part of this contract. Any failure of the Contractor to take the actions described and acknowledged in this paragraph will not relieve the Contractor from responsibility for estimating properly the difficulty and cost of successfully performing the work, or for proceeding to successfully perform the work without additional expense to the PHA.

- (b) The PHA assumes no responsibility for any conclusions or interpretations made by the Contractor based on the information made available by the PHA. Nor does the PHA assume responsibility for any understanding reached or representation made concerning conditions which can affect the work by any of its officers or agents before the execution of this contract, unless that understanding or representation is expressly stated in this contract.

#### 8. Differing Site Conditions

- (a) The Contractor shall promptly, and before the conditions are disturbed, give a written notice to the Contracting Officer of (1) subsurface or latent physical conditions at the site which differ materially from those indicated in this contract, or (2) unknown physical conditions at the site(s), of an unusual nature, which differ materially from those ordinarily encountered and generally recognized as inhering in work of the character provided for in the contract.
- (b) The Contracting Officer shall investigate the site conditions promptly after receiving the notice. Work shall not proceed at the affected site, except at the Contractor's risk, until the Contracting Officer has provided written instructions to the Contractor. If the conditions do materially so differ and cause an increase or decrease in the Contractor's cost of, or the time required for, performing any part of the work under this contract, whether or not changed as a result of the conditions, the Contractor shall file a claim in writing to the PHA within ten days after receipt of such instructions and, in any event, before proceeding with the work. An equitable adjustment in the contract price, the delivery schedule, or both shall be made under this clause and the contract modified in writing accordingly.
- (c) No request by the Contractor for an equitable adjustment to the contract under this clause shall be allowed, unless the Contractor has given the written notice required; provided, that the time prescribed in (a) above for giving written notice may be extended by the Contracting Officer.
- (d) No request by the Contractor for an equitable adjustment to the contract for differing site conditions shall be allowed if made after final payment under this contract.

#### 9. Specifications and Drawings for Construction

- (a) The Contractor shall keep on the work site a copy of the drawings and specifications and shall at all times give the Contracting Officer access thereto. Anything mentioned in the specifications and not shown on the drawings, or shown on the drawings and not mentioned in the specifications, shall be of like effect as if shown or mentioned in both. In case of difference between drawings and specifications, the specifications shall govern. In case of discrepancy in the figures, in the drawings, or in the specifications, the matter shall be required in the planning and production of the work. Such

promptly submitted to the Contracting Officer, who shall promptly make a determination in writing. Any adjustment by the Contractor without such a determination shall be at its own risk and expense. The Contracting Officer shall furnish from time to time such detailed drawings and other information as considered necessary, unless otherwise provided.

- (b) Wherever in the specifications or upon the drawings the words 'directed', 'required', 'ordered', 'designated', 'prescribed', or words of like import are used, it shall be understood that the 'direction', 'requirement', 'order', 'designation', or 'prescription', of the Contracting Officer is intended and similarly the words 'approved', 'acceptable', 'satisfactory', or words of like import shall mean 'approved by', or 'acceptable to', or 'satisfactory to' the Contracting Officer, unless otherwise expressly stated.
- (c) Where 'as shown', 'as indicated', 'as detailed', or words of similar import are used, it shall be understood that the reference is made to the drawings accompanying this contract unless stated otherwise. The word 'provided' as used herein shall be understood to mean 'provide complete in place' that is 'furnished and installed'.
- (d) 'Shop drawings' means drawings, submitted to the PHA by the Contractor, subcontractor, or any lower tier subcontractor, showing in detail (1) the proposed fabrication and assembly of structural elements and (2) the installation (i.e., form, fit, and attachment details) of materials of equipment. It includes drawings, diagrams, layouts, schematics, descriptive literature, illustrations, schedules, performance and test data, and similar materials furnished by the Contractor to explain in detail specific portions of the work required by the contract. The PHA may duplicate, use, and disclose in any manner and for any purpose shop drawings delivered under this contract.
- (e) If this contract requires shop drawings, the Contractor shall coordinate all such drawings, and review them for accuracy, completeness, and compliance with other contract requirements and shall indicate its approval thereon as evidence of such coordination and review. Shop drawings submitted to the Contracting Officer without evidence of the Contractor's approval may be returned for resubmission. The Contracting Officer will indicate an approval or disapproval of the shop drawings and if not approved as submitted shall indicate the PHA's reasons therefore. Any work done before such approval shall be at the Contractor's risk. Approval by the Contracting Officer shall not relieve the Contractor from responsibility for any errors or omissions in such drawings, nor from responsibility for complying with the requirements of this contract, except with respect to variations described and approved in accordance with (f) below.
- (f) If shop drawings show variations from the contract requirements, the Contractor shall describe such variations in writing, separate from the drawings, at the time of submission. If the Architect approves any such variation and the Contracting Officer concurs, the Contracting Officer shall issue an appropriate modification to the contract, except that, if the variation is minor or does not involve a change in price or in time of performance, a modification need not be issued.
- (g) It shall be the responsibility of the Contractor to make timely requests of the PHA for such large scale and full size drawings, color schemes, and other additional information, not already in his possession, which shall be requests may be submitted as the need arises, but each

such request shall be filed in ample time to permit appropriate action to be taken by all parties involved so as to avoid delay.

- (h) The Contractor shall submit to the Contracting Officer for approval four copies (unless otherwise indicated) of all shop drawings as called for under the various headings of these specifications. Three sets (unless otherwise indicated) of all shop drawings, will be retained by the PHA and one set will be returned to the Contractor. As required by the Contracting Officer, the Contractor, upon completing the work under this contract, shall furnish a complete set of all shop drawings as finally approved. These drawings shall show all changes and revisions made up to the time the work is completed and accepted.
- (i) This clause shall be included in all subcontracts at any tier. It shall be the responsibility of the Contractor to ensure that all shop drawings prepared by subcontractors are submitted to the Contracting Officer.

#### 10. As-Built Drawings

- (a) "As-built drawings," as used in this clause, means drawings submitted by the Contractor or subcontractor at any tier to show the construction of a particular structure or work as actually completed under the contract. "As-built drawings" shall be synonymous with "Record drawings."
- (b) As required by the Contracting Officer, the Contractor shall provide the Contracting Officer accurate information to be used in the preparation of permanent as-built drawings. For this purpose, the Contractor shall record on one set of contract drawings all changes from the installations originally indicated, and record final locations of underground lines by depth from finish grade and by accurate horizontal offset distances to permanent surface improvements such as buildings, curbs, or edges of walks.
- (c) This clause shall be included in all subcontracts at any tier. It shall be the responsibility of the Contractor to ensure that all as-built drawings prepared by subcontractors are submitted to the Contracting Officer.

#### 11. Material and Workmanship

- (a) All equipment, material, and articles furnished under this contract shall be new and of the most suitable grade for the purpose intended, unless otherwise specifically provided in this contract. References in the contract to equipment, material, articles, or patented processes by trade name, make, or catalog number, shall be regarded as establishing a standard of quality and shall not be construed as limiting competition. The Contractor may, at its option, use any equipment, material, article, or process that, in the judgment of, and as approved by the Contracting Officer, is equal to that named in the specifications, unless otherwise specifically provided in this contract.
- (b) Approval of equipment and materials.
- (1) The Contractor shall obtain the Contracting Officer's approval of the machinery and mechanical and other equipment to be incorporated into the work. When requesting approval, the Contractor shall furnish to the Contracting Officer the name of the manufacturer, the model number, and other information concerning the performance, capacity, nature, and rating of the machinery and mechanical and other equipment. Before installing the work, the Contractor shall

When required by this contract or by the Contracting Officer, the Contractor shall also obtain the Contracting Officer's approval of the material or articles which the Contractor contemplates incorporating into the work. When requesting approval, the Contractor shall provide full information concerning the material or articles. Machinery, equipment, material, and articles that do not have the required approval shall be installed or used at the risk of subsequent rejection.

- (2) When required by the specifications or the Contracting Officer, the Contractor shall submit appropriately marked samples (and certificates related to them) for approval at the Contractor's expense, with all shipping charges prepaid. The Contractor shall label, or otherwise properly mark on the container, the material or product represented, its place of origin, the name of the producer, the Contractor's name, and the identification of the construction project for which the material or product is intended to be used.
- (3) Certificates shall be submitted in triplicate, describing each sample submitted for approval and certifying that the material, equipment or accessory complies with contract requirements. The certificates shall include the name and brand of the product, name of manufacturer, and the location where produced.
- (4) Approval of a sample shall not constitute a waiver of the PHA right to demand full compliance with contract requirements. Materials, equipment and accessories may be rejected for cause even though samples have been approved.
- (5) Wherever materials are required to comply with recognized standards or specifications, such specifications shall be accepted as establishing the technical qualities and testing methods, but shall not govern the number of tests required to be made nor modify other contract requirements. The Contracting Officer may require laboratory test reports on items submitted for approval or may approve materials on the basis of data submitted in certificates with samples. Check tests will be made on materials delivered for use only as frequently as the Contracting Officer determines necessary to insure compliance of materials with the specifications. The Contractor will assume all costs of retesting materials which fail to meet contract requirements and/or testing materials offered in substitution for those found deficient.
- (6) After approval, samples will be kept in the Project office until completion of work. They may be built into the work after a substantial quantity of the materials they represent has been built in and accepted.
- (c) Requirements concerning lead-based paint. The Contractor shall comply with the requirements concerning lead-based paint contained in the Lead-Based Paint Poisoning Prevention Act (42 U.S.C. 4821-4846) as implemented by 24 CFR Part 35.

#### 12. Permits and Codes

- (a) The Contractor shall give all notices and comply with all applicable laws, ordinances, codes, rules and regulations. Notwithstanding the requirement of the Contractor to comply with the drawings and specifications in the contract, all work installed shall comply with all applicable codes and regulations as amended by any

examine the drawings and the specifications for

compliance with applicable codes and regulations bearing on the work and shall immediately report any discrepancy it may discover to the Contracting Officer. Where the requirements of the drawings and specifications fail to comply with the applicable code or regulation, the Contracting Officer shall modify the contract by change order pursuant to the clause entitled Changes herein to conform to the code or regulation.

- (b) The Contractor shall secure and pay for all permits, fees, and licenses necessary for the proper execution and completion of the work. Where the PHA can arrange for the issuance of all or part of these permits, fees and licenses, without cost to the Contractor, the contract amount shall be reduced accordingly.

### 13. Health, Safety, and Accident Prevention

- (a) In performing this contract, the Contractor shall:
- (1) Ensure that no laborer or mechanic shall be required to work in surroundings or under working conditions which are unsanitary, hazardous, or dangerous to his/her health and/or safety as determined under construction safety and health standards promulgated by the Secretary of Labor by regulation;
  - (2) Protect the lives, health, and safety of other persons;
  - (3) Prevent damage to property, materials, supplies, and equipment; and,
  - (4) Avoid work interruptions.
- (b) For these purposes, the Contractor shall:
- (1) Comply with regulations and standards issued by the Secretary of Labor at 29 CFR Part 1926. Failure to comply may result in imposition of sanctions pursuant to the Contract Work Hours and Safety Standards Act (Public Law 91-54, 83 Stat. 96), 40 U.S.C. 3701 et seq.; and
  - (2) Include the terms of this clause in every subcontract so that such terms will be binding on each subcontractor.
- (c) The Contractor shall maintain an accurate record of exposure data on all accidents incident to work performed under this contract resulting in death, traumatic injury, occupational disease, or damage to property, materials, supplies, or equipment, and shall report this data in the manner prescribed by 29 CFR Part 1904.
- (d) The Contracting Officer shall notify the Contractor of any noncompliance with these requirements and of the corrective action required. This notice, when delivered to the Contractor or the Contractor's representative at the site of the work, shall be deemed sufficient notice of the noncompliance and corrective action required. After receiving the notice, the Contractor shall immediately take corrective action. If the Contractor fails or refuses to take corrective action promptly, the Contracting Officer may issue an order stopping all or part of the work until satisfactory corrective action has been taken. The Contractor shall not base any claim or request for equitable adjustment for additional time or money on any stop order issued under these circumstances.
- (e) The Contractor shall be responsible for its subcontractors' compliance with the provisions of this clause. The Contractor shall take such action with respect to any subcontract as the PHA, the Secretary of Housing and Urban Development, or the Secretary of Labor shall direct as a means of enforcing such provisions.

- (f) New work which connects to existing work

### 14. Temporary Heating

The Contractor shall provide and pay for temporary heating, covering, and enclosures necessary to properly protect all work and materials against damage by dampness and cold, to dry out the work, and to facilitate the completion of the work. Any permanent heating equipment used shall be turned over to the PHA in the condition and at the time required by the specifications.

### 15. Availability and Use of Utility Services

- (a) The PHA shall make all reasonably required amounts of utilities available to the Contractor from existing outlets and supplies, as specified in the contract. Unless otherwise provided in the contract, the amount of each utility service consumed shall be charged to or paid for by the Contractor at prevailing rates charged to the PHA or, where the utility is produced by the PHA, at reasonable rates determined by the Contracting Officer. The Contractor shall carefully conserve any utilities furnished without charge.
- (b) The Contractor, at its expense and in a manner satisfactory to the Contracting Officer, shall install and maintain all necessary temporary connections and distribution lines, and all meters required to measure the amount of each utility used for the purpose of determining charges. Before final acceptance of the work by the PHA, the Contractor shall remove all the temporary connections, distribution lines, meters, and associated paraphernalia.

### 16. Protection of Existing Vegetation, Structures, Equipment, Utilities, and Improvements

- (a) The Contractor shall preserve and protect all structures, equipment, and vegetation (such as trees, shrubs, and grass) on or adjacent to the work site, which are not to be removed under this contract, and which do not unreasonably interfere with the work required under this contract.
- (b) The Contractor shall only remove trees when specifically authorized to do so, and shall avoid damaging vegetation that will remain in place. If any limbs or branches of trees are broken during performance of this contract, or by the careless operation of equipment, or by workmen, the Contractor shall trim those limbs or branches with a clean cut and paint the cut with a tree-pruning compound as directed by the Contracting Officer.
- (c) The Contractor shall protect from damage all existing improvements and utilities (1) at or near the work site and (2) on adjacent property of a third party, the locations of which are made known to or should be known by the Contractor. Prior to disturbing the ground at the construction site, the Contractor shall ensure that all underground utility lines are clearly marked.
- (d) The Contractor shall shore up, brace, underpin, secure, and protect as necessary all foundations and other parts of existing structures adjacent to, adjoining, and in the vicinity of the site, which may be affected by the excavations or other operations connected with the construction of the project.
- (e) Any equipment temporarily removed as a result of work under this contract shall be protected, cleaned, and replaced in the same condition as at the time of award of this contract.

shall correspond in all respects with that to which it

connects and/or be similar to existing work unless otherwise required by the specifications.

- (g) No structural members shall be altered or in any way weakened without the written authorization of the Contracting Officer, unless such work is clearly specified in the plans or specifications.
- (h) If the removal of the existing work exposes discolored or unfinished surfaces, or work out of alignment, such surfaces shall be refinished, or the material replaced as necessary to make the continuous work uniform and harmonious. This, however, shall not be construed to require the refinishing or reconstruction of dissimilar finishes previously exposed, or finished surfaces in good condition, but in different planes or on different levels when brought together by the removal of intervening work, unless such refinishing or reconstruction is specified in the plans or specifications.
- (i) The Contractor shall give all required notices to any adjoining or adjacent property owner or other party before the commencement of any work.
- (j) The Contractor shall indemnify and save harmless the PHA from any damages on account of settlement or the loss of lateral support of adjoining property, any damages from changes in topography affecting drainage, and from all loss or expense and all damages for which the PHA may become liable in consequence of such injury or damage to adjoining and adjacent structures and their premises.
- (k) The Contractor shall repair any damage to vegetation, structures, equipment, utilities, or improvements, including those that are the property of a third party, resulting from failure to comply with the requirements of this contract or failure to exercise reasonable care in performing the work. If the Contractor fails or refuses to repair the damage promptly, the Contracting Officer may have the necessary work performed and charge the cost to the Contractor.

#### 17. Temporary Buildings and Transportation of Materials

- (a) Temporary buildings (e.g., storage sheds, shops, offices, sanitary facilities) and utilities may be erected by the Contractor only with the approval of the Contracting Officer and shall be built with labor and materials furnished by the Contractor without expense to the PHA. The temporary buildings and utilities shall remain the property of the Contractor and shall be removed by the Contractor at its expense upon completion of the work. With the written consent of the Contracting Officer, the buildings and utilities may be abandoned and need not be removed.
- (b) The Contractor shall, as directed by the Contracting Officer, use only established roadways, or use temporary roadways constructed by the Contractor when and as authorized by the Contracting Officer. When materials are transported in prosecuting the work, vehicles shall not be loaded beyond the loading capacity recommended by the manufacturer of the vehicle or prescribed by any federal, state, or local law or regulation. When it is necessary to cross curbs or sidewalks, the Contractor shall protect them from damage. The Contractor shall repair or pay for the repair of any damaged curbs, sidewalks, or roads.

#### 18. Clean Air and Water

The contractor shall comply with the Clean Air Act, as

- (f) The PHA may conduct routine inspections of the construction site on a daily basis.

amended, 42 USC 7401 et seq., the Federal Water Pollution Control Water Act, as amended, 33 U.S.C. 1251 et seq., and standards issued pursuant thereto in the facilities in which this contract is to be performed.

#### 19. Energy Efficiency

The Contractor shall comply with mandatory standards and policies relating to energy efficiency which are contained in the energy conservation plan issued in compliance with the Energy Policy and Conservation Act (Pub.L. 94-163) for the State in which the work under the contract is performed.

#### 20. Inspection and Acceptance of Construction

- (a) Definitions. As used in this clause -
  - (1) "Acceptance" means the act of an authorized representative of the PHA by which the PHA approves and assumes ownership of the work performed under this contract. Acceptance may be partial or complete.
  - (2) "Inspection" means examining and testing the work performed under the contract (including, when appropriate, raw materials, equipment, components, and intermediate assemblies) to determine whether it conforms to contract requirements.
  - (3) "Testing" means that element of inspection that determines the properties or elements, including functional operation of materials, equipment, or their components, by the application of established scientific principles and procedures.
- (b) The Contractor shall maintain an adequate inspection system and perform such inspections as will ensure that the work performed under the contract conforms to contract requirements. All work is subject to PHA inspection and test at all places and at all reasonable times before acceptance to ensure strict compliance with the terms of the contract.
- (c) PHA inspections and tests are for the sole benefit of the PHA and do not: (1) relieve the Contractor of responsibility for providing adequate quality control measures; (2) relieve the Contractor of responsibility for loss or damage of the material before acceptance; (3) constitute or imply acceptance; or, (4) affect the continuing rights of the PHA after acceptance of the completed work under paragraph (j) below.
- (d) The presence or absence of the PHA inspector does not relieve the Contractor from any contract requirement, nor is the inspector authorized to change any term or condition of the specifications without the Contracting Officer's written authorization. All instructions and approvals with respect to the work shall be given to the Contractor by the Contracting Officer.
- (e) The Contractor shall promptly furnish, without additional charge, all facilities, labor, and material reasonably needed for performing such safe and convenient inspections and tests as may be required by the Contracting Officer. The PHA may charge to the Contractor any additional cost of inspection or test when work is not ready at the time specified by the Contractor for inspection or test, or when prior rejection makes reinspection or retest necessary. The PHA shall perform all inspections and tests in a manner that will not unnecessarily delay the work. Special, full size, and performance tests shall be performed as described in the contract.
- (g) The Contractor shall, without charge, replace or correct work found by the PHA not to conform to

contract requirements, unless the PHA decides that it is in its interest to accept the work with an appropriate adjustment in contract price. The Contractor shall promptly segregate and remove rejected material from the premises.

- (h) If the Contractor does not promptly replace or correct rejected work, the PHA may (1) by contract or otherwise, replace or correct the work and charge the cost to the Contractor, or (2) terminate for default the Contractor's right to proceed.
- (i) If any work requiring inspection is covered up without approval of the PHA, it must, if requested by the Contracting Officer, be uncovered at the expense of the Contractor. If at any time before final acceptance of the entire work, the PHA considers it necessary or advisable, to examine work already completed by removing or tearing it out, the Contractor, shall on request, promptly furnish all necessary facilities, labor, and material. If such work is found to be defective or nonconforming in any material respect due to the fault of the Contractor or its subcontractors, the Contractor shall defray all the expenses of the examination and of satisfactory reconstruction. If, however, such work is found to meet the requirements of the contract, the Contracting Officer shall make an equitable adjustment to cover the cost of the examination and reconstruction, including, if completion of the work was thereby delayed, an extension of time.
- (j) The Contractor shall notify the Contracting Officer, in writing, as to the date when in its opinion all or a designated portion of the work will be substantially completed and ready for inspection. If the Architect determines that the state of preparedness is as represented, the PHA will promptly arrange for the inspection. Unless otherwise specified in the contract, the PHA shall accept, as soon as practicable after completion and inspection, all work required by the contract or that portion of the work the Contracting Officer determines and designates can be accepted separately. Acceptance shall be final and conclusive except for latent defects, fraud, gross mistakes amounting to fraud, or the PHA's right under any warranty or guarantee.

#### 21. Use and Possession Prior to Completion

- (a) The PHA shall have the right to take possession of or use any completed or partially completed part of the work. Before taking possession of or using any work, the Contracting Officer shall furnish the Contractor a list of items of work remaining to be performed or corrected on those portions of the work that the PHA intends to take possession of or use. However, failure of the Contracting Officer to list any item of work shall not relieve the Contractor of responsibility for complying with the terms of the contract. The PHA's possession or use shall not be deemed an acceptance of any work under the contract.
- (b) While the PHA has such possession or use, the Contractor shall be relieved of the responsibility for (1) the loss of or damage to the work resulting from the PHA's possession or use, notwithstanding the terms of the clause entitled Permits and Codes herein; (2) all maintenance costs on the areas occupied; and, (3) furnishing heat, light, power, and water used in the areas occupied without proper remuneration therefore. If prior possession or use by the PHA delays the progress of the
- (h) Unless a defect is caused by the negligence of the Contractor or subcontractor or supplier at any tier, the

work or causes additional expense to the Contractor, an equitable adjustment shall be made in the contract price or the time of completion, and the contract shall be modified in writing accordingly.

#### 22. Warranty of Title

The Contractor warrants good title to all materials, supplies, and equipment incorporated in the work and agrees to deliver the premises together with all improvements thereon free from any claims, liens or charges, and agrees further that neither it nor any other person, firm or corporation shall have any right to a lien upon the premises or anything appurtenant thereto.

#### 23. Warranty of Construction

- (a) In addition to any other warranties in this contract, the Contractor warrants, except as provided in paragraph (j) of this clause, that work performed under this contract conforms to the contract requirements and is free of any defect in equipment, material, or workmanship performed by the Contractor or any subcontractor or supplier at any tier. This warranty shall continue for a period of \_\_\_\_\_ (one year unless otherwise indicated) from the date of final acceptance of the work. If the PHA takes possession of any part of the work before final acceptance, this warranty shall continue for a period of (one year unless otherwise indicated) from the date that the PHA takes possession.
- (b) The Contractor shall remedy, at the Contractor's expense, any failure to conform, or any defect. In addition, the Contractor shall remedy, at the Contractor's expense, any damage to PHA-owned or controlled real or personal property when the damage is the result of—
- (1) The Contractor's failure to conform to contract requirements; or
  - (2) Any defects of equipment, material, workmanship or design furnished by the Contractor.
- (c) The Contractor shall restore any work damaged in fulfilling the terms and conditions of this clause. The Contractor's warranty with respect to work repaired or replaced will run for (one year unless otherwise indicated) from the date of repair or replacement.
- (d) The Contracting Officer shall notify the Contractor, in writing, within a reasonable time after the discovery of any failure, defect or damage.
- (e) If the Contractor fails to remedy any failure, defect, or damage within a reasonable time after receipt of notice, the PHA shall have the right to replace, repair or otherwise remedy the failure, defect, or damage at the Contractor's expense.
- (f) With respect to all warranties, express or implied, from subcontractors, manufacturers, or suppliers for work performed and materials furnished under this contract, the Contractor shall:
- (1) Obtain all warranties that would be given in normal commercial practice;
  - (2) Require all warranties to be executed in writing, for the benefit of the PHA; and,
  - (3) Enforce all warranties for the benefit of the PHA.
- (g) In the event the Contractor's warranty under paragraph (a) of this clause has expired, the PHA may bring suit at its own expense to enforce a subcontractor's, manufacturer's or supplier's warranty.
- Contractor shall not be liable for the repair of any defect of material or design furnished by the PHA nor for the

repair of any damage that results from any defect in PHA furnished material or design.

- (i) Notwithstanding any provisions herein to the contrary, the establishment of the time periods in paragraphs (a) and (c) above relate only to the specific obligation of the Contractor to correct the work, and have no relationship to the time within which its obligation to comply with the contract may be sought to be enforced, nor to the time within which proceedings may be commenced to establish the Contractor's liability with respect to its obligation other than specifically to correct the work.
- (j) This warranty shall not limit the PHA's rights under the Inspection and Acceptance of Construction clause of this contract with respect to latent defects, gross mistakes or fraud.

#### 24. Prohibition Against Liens

The Contractor is prohibited from placing a lien on the PHA's property. This prohibition shall apply to all subcontractors at any tier and all materials suppliers.

#### Administrative Requirements

#### 25. Contract Period

The Contractor shall complete all work required under this contract within \_\_\_\_\_ calendar days of the effective date of the contract, or within the time schedule established in the notice to proceed issued by the Contracting Officer.

#### 26. Order of Provisions

In the event of a conflict between these General Conditions and the Specifications, the General Conditions shall prevail. In the event of a conflict between the contract and any applicable state or local law or regulation, the state or local law or regulation shall prevail; provided that such state or local law or regulation does not conflict with, or is less restrictive than applicable federal law, regulation, or Executive Order. In the event of such a conflict, applicable federal law, regulation, and Executive Order shall prevail.

#### 27. Payments

- (a) The PHA shall pay the Contractor the price as provided in this contract.
- (b) The PHA shall make progress payments approximately every 30 days as the work proceeds, on estimates of work accomplished which meets the standards of quality established under the contract, as approved by the Contracting Officer. The PHA may, subject to written determination and approval of the Contracting Officer, make more frequent payments to contractors which are qualified small businesses.
- (c) Before the first progress payment under this contract, the Contractor shall furnish, in such detail as requested by the Contracting Officer, a breakdown of the total contract price showing the amount included therein for each principal category of the work, which shall substantiate the payment amount requested in order to provide a basis for determining progress payments. The breakdown shall be approved by the Contracting Officer and must be Material delivered to the Contractor at locations other than the site may also be taken into consideration if the Contractor furnishes satisfactory evidence that (1) it has

acceptable to HUD. If the contract covers more than one project, the Contractor shall furnish a separate breakdown for each. The values and quantities employed in making up this breakdown are for determining the amount of progress payments and shall not be construed as a basis for additions to or deductions from the contract price. The Contractor shall prorate its overhead and profit over the construction period of the contract.

- (d) The Contractor shall submit, on forms provided by the PHA, periodic estimates showing the value of the work performed during each period based upon the approved breakdown of the contract price. Such estimates shall be submitted not later than \_\_\_\_\_ days in advance of the date set for payment and are subject to correction and revision as required. The estimates must be approved by the Contracting Officer with the concurrence of the Architect prior to payment. If the contract covers more than one project, the Contractor shall furnish a separate progress payment estimate for each.

- (e) Along with each request for progress payments and the required estimates, the Contractor shall furnish the following certification, or payment shall not be made: I hereby certify, to the best of my knowledge and belief, that:

- (1) The amounts requested are only for performance in accordance with the specifications, terms, and conditions of the contract;
- (2) Payments to subcontractors and suppliers have been made from previous payments received under the contract, and timely payments will be made from the proceeds of the payment covered by this certification, in accordance with subcontract agreements; and,
- (3) This request for progress payments does not include any amounts which the prime contractor intends to withhold or retain from a subcontractor or supplier in accordance with the terms and conditions of the subcontract.

Name: \_\_\_\_\_

Title: \_\_\_\_\_

Date: \_\_\_\_\_

- (f) Except as otherwise provided in State law, the PHA shall retain ten (10) percent of the amount of progress payments until completion and acceptance of all work under the contract; except, that if upon completion of 50 percent of the work, the Contracting Officer, after consulting with the Architect, determines that the Contractor's performance and progress are satisfactory, the PHA may make the remaining payments in full for the work subsequently completed. If the Contracting Officer subsequently determines that the Contractor's performance and progress are unsatisfactory, the PHA shall reinstate the ten (10) percent (or other percentage as provided in State law) retainage until such time as the Contracting Officer determines that performance and progress are satisfactory.
- (g) The Contracting Officer may authorize material delivered on the site and preparatory work done to be taken into consideration when computing progress payments.

acquired title to such material; (2) the material is properly stored in a bonded warehouse, storage yard, or similar suitable place as may be approved by the Contracting

Officer; (3) the material is insured to cover its full value; and (4) the material will be used to perform this contract. Before any progress payment which includes delivered material is made, the Contractor shall furnish such documentation as the Contracting Officer may require to assure the protection of the PHA's interest in such materials. The Contractor shall remain responsible for such stored material notwithstanding the transfer of title to the PHA.

- (h) All material and work covered by progress payments made shall, at the time of payment become the sole property of the PHA, but this shall not be construed as (1) relieving the Contractor from the sole responsibility for all material and work upon which payments have been made or the restoration of any damaged work; or, (2) waiving the right of the PHA to require the fulfillment of all of the terms of the contract. In the event the work of the Contractor has been damaged by other contractors or persons other than employees of the PHA in the course of their employment, the Contractor shall restore such damaged work without cost to the PHA and to seek redress for its damage only from those who directly caused it.
- (i) The PHA shall make the final payment due the Contractor under this contract after (1) completion and final acceptance of all work; and (2) presentation of release of all claims against the PHA arising by virtue of this contract, other than claims, in stated amounts, that the Contractor has specifically excepted from the operation of the release. Each such exception shall embrace no more than one claim, the basis and scope of which shall be clearly defined. The amounts for such excepted claims shall not be included in the request for final payment. A release may also be required of the assignee if the Contractor's claim to amounts payable under this contract has been assigned.
- (j) Prior to making any payment, the Contracting Officer may require the Contractor to furnish receipts or other evidence of payment from all persons performing work and supplying material to the Contractor, if the Contracting Officer determines such evidence is necessary to substantiate claimed costs.
- (k) The PHA shall not: (1) determine or adjust any claims for payment or disputes arising there under between the Contractor and its subcontractors or material suppliers; or, (2) withhold any moneys for the protection of the subcontractors or material suppliers. The failure or refusal of the PHA to withhold moneys from the Contractor shall in nowise impair the obligations of any surety or sureties under any bonds furnished under this contract.

## 28. Contract Modifications

- (a) Only the Contracting Officer has authority to modify any term or condition of this contract. Any contract modification shall be authorized in writing.
- (b) The Contracting Officer may modify the contract unilaterally (1) pursuant to a specific authorization stated in a contract clause (e.g., Changes); or (2) for administrative matters which do not change the rights or responsibilities of the parties (e.g., change in the PHA address). All other contract modifications shall be in the form of supplemental agreements signed by the
  - (1) Direct Costs. Materials (list individual items, the quantity and unit cost of each, and the aggregate cost); Transportation and delivery costs associated with materials; Labor breakdowns by hours or unit

Contractor and the Contracting Officer.

- (c) When a proposed modification requires the approval of HUD prior to its issuance (e.g., a change order that exceeds the PHA's approved threshold), such modification shall not be effective until the required approval is received by the PHA.

## 29. Changes

- (a) The Contracting Officer may, at any time, without notice to the sureties, by written order designated or indicated to be a change order, make changes in the work within the general scope of the contract including changes:
  - (1) In the specifications (including drawings and designs);
  - (2) In the method or manner of performance of the work;
  - (3) PHA-furnished facilities, equipment, materials, services, or site; or,
  - (4) Directing the acceleration in the performance of the work.
- (b) Any other written order or oral order (which, as used in this paragraph (b), includes direction, instruction, interpretation, or determination) from the Contracting Officer that causes a change shall be treated as a change order under this clause; provided, that the Contractor gives the Contracting Officer written notice stating (1) the date, circumstances and source of the order and (2) that the Contractor regards the order as a change order.
- (c) Except as provided in this clause, no order, statement or conduct of the Contracting Officer shall be treated as a change under this clause or entitle the Contractor to an equitable adjustment.
- (d) If any change under this clause causes an increase or decrease in the Contractor's cost of, or the time required for the performance of any part of the work under this contract, whether or not changed by any such order, the Contracting Officer shall make an equitable adjustment and modify the contract in writing. However, except for an adjustment based on defective specifications, no proposal for any change under paragraph (b) above shall be allowed for any costs incurred more than 20 days (5 days for oral orders) before the Contractor gives written notice as required. In the case of defective specifications for which the PHA is responsible, the equitable adjustment shall include any increased cost reasonably incurred by the Contractor in attempting to comply with the defective specifications.
- (e) The Contractor must assert its right to an adjustment under this clause within 30 days after (1) receipt of a written change order under paragraph (a) of this clause, or (2) the furnishing of a written notice under paragraph (b) of this clause, by submitting a written statement describing the general nature and the amount of the proposal. If the facts justify it, the Contracting Officer may extend the period for submission. The proposal may be included in the notice required under paragraph (b) above. No proposal by the Contractor for an equitable adjustment shall be allowed if asserted after final payment under this contract.
- (f) The Contractor's written proposal for equitable adjustment shall be submitted in the form of a lump sum proposal supported with an itemized breakdown of all increases and decreases in the contract in at least the following details:
  - costs (identified with specific work to be performed);
  - Construction equipment exclusively necessary for the change;
  - Costs of preparation and/ or revision to shop drawings resulting from the change;
  - Worker's

Compensation and Public Liability Insurance; Employment taxes under FICA and FUTA; and, Bond Costs when size of change warrants revision.

- (2) Indirect Costs. Indirect costs may include overhead, general and administrative expenses, and fringe benefits not normally treated as direct costs.
- (3) Profit. The amount of profit shall be negotiated and may vary according to the nature, extent, and complexity of the work required by the change.

The allowability of the direct and indirect costs shall be determined in accordance with the Contract Cost Principles and Procedures for Commercial Firms in Part 31 of the Federal Acquisition Regulation (48 CFR 1-31), as implemented by HUD Handbook 2210.18, in effect on the date of this contract. The Contractor shall not be allowed a profit on the profit received by any subcontractor. Equitable adjustments for deleted work shall include a credit for profit and may include a credit for indirect costs. On proposals covering both increases and decreases in the amount of the contract, the application of indirect costs and profit shall be on the net-change in direct costs for the Contractor or subcontractor performing the work.

- (g) The Contractor shall include in the proposal its request for time extension (if any), and shall include sufficient information and dates to demonstrate whether and to what extent the change will delay the completion of the contract in its entirety.
- (h) The Contracting Officer shall act on proposals within 30 days after their receipt, or notify the Contractor of the date when such action will be taken.
- (i) Failure to reach an agreement on any proposal shall be a dispute under the clause entitled Disputes herein. Nothing in this clause, however, shall excuse the Contractor from proceeding with the contract as changed.
- (j) Except in an emergency endangering life or property, no change shall be made by the Contractor without a prior order from the Contracting Officer.

### 30. Suspension of Work

- (a) The Contracting Officer may order the Contractor in writing to suspend, delay, or interrupt all or any part of the work of this contract for the period of time that the Contracting Officer determines appropriate for the convenience of the PHA.
- (b) If the performance of all or any part of the work is, for an unreasonable period of time, suspended, delayed, or interrupted (1) by an act of the Contracting Officer in the administration of this contract, or (2) by the Contracting Officer's failure to act within the time specified (or within a reasonable time if not specified) in this contract an adjustment shall be made for any increase in the cost of performance of the contract (excluding profit) necessarily caused by such unreasonable suspension, delay, or interruption and the contract modified in writing accordingly. However, no adjustment shall be made under this clause for any suspension, delay, or interruption to the extent that performance would have been so suspended, delayed, or interrupted by any other cause, including the fault or negligence of the Contractor or for which any equitable adjustment is provided for or excluded under any other provision of this contract.
- (c) A claim under this clause shall not be allowed (1) for any proceed with the work (or separable part of the work) that has been delayed. In this event, the PHA may take over the work and complete it, by contract or otherwise, and

costs incurred more than 20 days before the Contractor shall have notified the Contracting Officer in writing of the act or failure to act involved (but this requirement shall not apply as to a claim resulting from a suspension order); and, (2) unless the claim, in an amount stated, is asserted in writing as soon as practicable after the termination of the suspension, delay, or interruption, but not later than the date of final payment under the contract.

### 31. Disputes

- (a) "Claim," as used in this clause, means a written demand or written assertion by one of the contracting parties seeking, as a matter of right, the payment of money in a sum certain, the adjustment or interpretation of contract terms, or other relief arising under or relating to the contract. A claim arising under the contract, unlike a claim relating to the contract, is a claim that can be resolved under a contract clause that provides for the relief sought by the claimant. A voucher, invoice, or other routine request for payment that is not in dispute when submitted is not a claim. The submission may be converted to a claim by complying with the requirements of this clause, if it is disputed either as to liability or amount or is not acted upon in a reasonable time.
- (b) Except for disputes arising under the clauses entitled Labor Standards - Davis Bacon and Related Acts, herein, all disputes arising under or relating to this contract, including any claims for damages for the alleged breach thereof which are not disposed of by agreement, shall be resolved under this clause.
- (c) All claims by the Contractor shall be made in writing and submitted to the Contracting Officer for a written decision. A claim by the PHA against the Contractor shall be subject to a written decision by the Contracting Officer.
- (d) The Contracting Officer shall, within 60 (unless otherwise indicated) days after receipt of the request, decide the claim or notify the Contractor of the date by which the decision will be made.
- (e) The Contracting Officer's decision shall be final unless the Contractor (1) appeals in writing to a higher level in the PHA in accordance with the PHA's policy and procedures, (2) refers the appeal to an independent mediator or arbitrator, or (3) files suit in a court of competent jurisdiction. Such appeal must be made within (30 unless otherwise indicated) days after receipt of the Contracting Officer's decision.
- (f) The Contractor shall proceed diligently with performance of this contract, pending final resolution of any request for relief, claim, appeal, or action arising under or relating to the contract, and comply with any decision of the Contracting Officer.

### 32. Default

- (a) If the Contractor refuses or fails to prosecute the work, or any separable part thereof, with the diligence that will insure its completion within the time specified in this contract, or any extension thereof, or fails to complete said work within this time, the Contracting Officer may, by written notice to the Contractor, terminate the right to

may take possession of and use any materials, equipment, and plant on the work site necessary for completing the work. The Contractor and its sureties shall

be liable for any damage to the PHA resulting from the Contractor's refusal or failure to complete the work within the specified time, whether or not the Contractor's right to proceed with the work is terminated. This liability includes any increased costs incurred by the PHA in completing the work.

- (b) The Contractor's right to proceed shall not be terminated or the Contractor charged with damages under this clause if—

- (1) The delay in completing the work arises from unforeseeable causes beyond the control and without the fault or negligence of the Contractor. Examples of such causes include (i) acts of God, or of the public enemy, (ii) acts of the PHA or other governmental entity in either its sovereign or contractual capacity, (iii) acts of another contractor in the performance of a contract with the PHA, (iv) fires, (v) floods, (vi) epidemics, (vii) quarantine restrictions, (viii) strikes, (ix) freight embargoes, (x) unusually severe weather, or (xi) delays of subcontractors or suppliers at any tier arising from unforeseeable causes beyond the control and without the fault or negligence of both the Contractor and the subcontractors or suppliers; and
- (2) The Contractor, within days (10 days unless otherwise indicated) from the beginning of such delay (unless extended by the Contracting Officer) notifies the Contracting Officer in writing of the causes of delay. The Contracting Officer shall ascertain the facts and the extent of the delay. If, in the judgment of the Contracting Officer, the findings of fact warrant such action, time for completing the work shall be extended by written modification to the contract. The findings of the Contracting Officer shall be reduced to a written decision which shall be subject to the provisions of the Disputes clause of this contract.

- (c) If, after termination of the Contractor's right to proceed, it is determined that the Contractor was not in default, or that the delay was excusable, the rights and obligations of the parties will be the same as if the termination had been for convenience of the PHA.

### 33. Liquidated Damages

- (a) If the Contractor fails to complete the work within the time specified in the contract, or any extension, as specified in the clause entitled Default of this contract, the Contractor shall pay to the PHA as liquidated damages, the sum of \$ \_\_\_\_\_ [Contracting Officer insert amount] for each day of delay. If different completion dates are specified in the contract for separate parts or stages of the work, the amount of liquidated damages shall be assessed on those parts or stages which are delayed. To the extent that the Contractor's delay or nonperformance is excused under another clause in this contract, liquidated damages shall not be due the PHA. The Contractor remains liable for damages caused other than by delay.
- (b) If the PHA terminates the Contractor's right to proceed, the resulting damage will consist of liquidated damages until such reasonable time as may be required for final

completion of the work together with any increased costs occasioned the PHA in completing the work.

- (c) If the PHA does not terminate the Contractor's right to proceed, the resulting damage will consist of liquidated damages until the work is completed or accepted.

### 34. Termination for Convenience

- (a) The Contracting Officer may terminate this contract in whole, or in part, whenever the Contracting Officer determines that such termination is in the best interest of the PHA. Any such termination shall be effected by delivery to the Contractor of a Notice of Termination specifying the extent to which the performance of the work under the contract is terminated, and the date upon which such termination becomes effective.
- (b) If the performance of the work is terminated, either in whole or in part, the PHA shall be liable to the Contractor for reasonable and proper costs resulting from such termination upon the receipt by the PHA of a properly presented claim setting out in detail: (1) the total cost of the work performed to date of termination less the total amount of contract payments made to the Contractor; (2) the cost (including reasonable profit) of settling and paying claims under subcontracts and material orders for work performed and materials and supplies delivered to the site, payment for which has not been made by the PHA to the Contractor or by the Contractor to the subcontractor or supplier; (3) the cost of preserving and protecting the work already performed until the PHA or assignee takes possession thereof or assumes responsibility therefore; (4) the actual or estimated cost of legal and accounting services reasonably necessary to prepare and present the termination claim to the PHA; and (5) an amount constituting a reasonable profit on the value of the work performed by the Contractor.
- (c) The Contracting Officer will act on the Contractor's claim within days (60 days unless otherwise indicated) of receipt of the Contractor's claim.
- (d) Any disputes with regard to this clause are expressly made subject to the provisions of the Disputes clause of this contract.

### 35. Assignment of Contract

The Contractor shall not assign or transfer any interest in this contract; except that claims for monies due or to become due from the PHA under the contract may be assigned to a bank, trust company, or other financial institution. Such assignments of claims shall only be made with the written concurrence of the Contracting Officer. If the Contractor is a partnership, this contract shall inure to the benefit of the surviving or remaining member(s) of such partnership as approved by the Contracting Officer.

### 36. Insurance

- (a) Before commencing work, the Contractor and each subcontractor shall furnish the PHA with certificates of insurance showing the following insurance is in force and will insure all operations under the Contract:
- (1) Workers' Compensation, in accordance with state or Territorial Workers' Compensation laws.
  - (2) Commercial General Liability with a combined single limit for bodily injury and property damage of not less than \$ \_\_\_\_\_ [Contracting Officer insert amount]

- per occurrence to protect the Contractor and each subcontractor against claims for bodily injury or death and damage to the property of others. This shall cover the use of all equipment, hoists, and vehicles on the site(s) not covered by Automobile Liability under (3) below. If the Contractor has a "claims-made" policy, then the following additional requirements apply: the policy must provide a "retroactive date" which must be on or before the execution date of the Contract; and the extended reporting period may not be less than five years following the completion date of the Contract.
- (3) Automobile Liability on owned and non-owned motor vehicles used on the site(s) or in connection therewith for a combined single limit for bodily injury and property damage of not less than \$\_\_\_\_\_ [Contracting Officer insert amount] per occurrence.
- (b) Before commencing work, the Contractor shall furnish the PHA with a certificate of insurance evidencing that Builder's Risk (fire and extended coverage) Insurance on all work in place and/or materials stored at the building site(s), including foundations and building equipment, is in force. The Builder's Risk Insurance shall be for the benefit of the Contractor and the PHA as their interests may appear and each shall be named in the policy or policies as an insured. The Contractor in installing equipment supplied by the PHA shall carry insurance on such equipment from the time the Contractor takes possession thereof until the Contract work is accepted by the PHA. The Builder's Risk Insurance need not be carried on excavations, piers, footings, or foundations until such time as work on the superstructure is started. It need not be carried on landscape work. Policies shall furnish coverage at all times for the full cash value of all completed construction, as well as materials in place and/or stored at the site(s), whether or not partial payment has been made by the PHA. The Contractor may terminate this insurance on buildings as of the date taken over for occupancy by the PHA. The Contractor is not required to carry Builder's Risk Insurance for modernization work which does not involve structural alterations or additions and where the PHA's existing fire and extended coverage policy can be endorsed to include such work.
- (c) All insurance shall be carried with companies which are financially responsible and admitted to do business in the State in which the project is located. If any such insurance is due to expire during the construction period, the Contractor (including subcontractors, as applicable) shall not permit the coverage to lapse and shall furnish evidence of coverage to the Contracting Officer. All certificates of insurance, as evidence of coverage, shall provide that no coverage may be canceled or non-renewed by the insurance company until at least 30 days prior written notice has been given to the Contracting Officer.

### 37. Subcontracts

- (a) Definitions. As used in this contract -
- (1) "Subcontract" means any contract, purchase order, or other purchase agreement, including modifications and change orders to the foregoing, entered into by a subcontractor to furnish supplies, materials, equipment, and services for the performance of the prime contract or a subcontract.

- (2) "Subcontractor" means any supplier, vendor, or firm that furnishes supplies, materials, equipment, or services to or for the Contractor or another subcontractor.
- (b) The Contractor shall not enter into any subcontract with any subcontractor who has been temporarily denied participation in a HUD program or who has been suspended or debarred from participating in contracting programs by any agency of the United States Government or of the state in which the work under this contract is to be performed.
- (c) The Contractor shall be as fully responsible for the acts or omissions of its subcontractors, and of persons either directly or indirectly employed by them as for the acts or omissions of persons directly employed by the Contractor.
- (d) The Contractor shall insert appropriate clauses in all subcontracts to bind subcontractors to the terms and conditions of this contract insofar as they are applicable to the work of subcontractors.
- (e) Nothing contained in this contract shall create any contractual relationship between any subcontractor and the PHA or between the subcontractor and HUD.

### 38. Subcontracting with Small and Minority Firms, Women's Business Enterprise, and Labor Surplus Area Firms

The Contractor shall take the following steps to ensure that, whenever possible, subcontracts are awarded to small business firms, minority firms, women's business enterprises, and labor surplus area firms:

- (a) Placing qualified small and minority businesses and women's business enterprises on solicitation lists;
- (b) Ensuring that small and minority businesses and women's business enterprises are solicited whenever they are potential sources;
- (c) Dividing total requirements, when economically feasible, into smaller tasks or quantities to permit maximum participation by small and minority businesses and women's business enterprises;
- (d) Establishing delivery schedules, where the requirements of the contract permit, which encourage participation by small and minority businesses and women's business enterprises; and
- (e) Using the services and assistance of the U.S. Small Business Administration, the Minority Business Development Agency of the U.S. Department of Commerce, and State and local governmental small business agencies.

### 39. Equal Employment Opportunity

During the performance of this contract, the Contractor agrees as follows:

- (a) The Contractor shall not discriminate against any employee or applicant for employment because of race, color, religion, sex, national origin, or handicap.
- (b) The Contractor shall take affirmative action to ensure that applicants are employed, and that employees are treated during employment without regard to their race, color, religion, sex, national origin, or handicap. Such action shall include, but not be limited to, (1) employment, (2) upgrading, (3) demotion, (4) transfer, (5) recruitment or recruitment advertising, (6) layoff or termination, (7) rates of pay or other forms of compensation, and (8) selection for training, including apprenticeship.

- (c) The Contractor shall post in conspicuous places available to employees and applicants for employment the notices to be provided by the Contracting Officer that explain this clause.
- (d) The Contractor shall, in all solicitations or advertisements for employees placed by or on behalf of the Contractor, state that all qualified applicants will receive consideration for employment without regard to race, color, religion, sex, national origin, or handicap.
- (e) The Contractor shall send, to each labor union or representative of workers with which it has a collective bargaining agreement or other contract or understanding, the notice to be provided by the Contracting Officer advising the labor union or workers' representative of the Contractor's commitments under this clause, and post copies of the notice in conspicuous places available to employees and applicants for employment.
- (f) The Contractor shall comply with Executive Order 11246, as amended, and the rules, regulations, and orders of the Secretary of Labor.
- (g) The Contractor shall furnish all information and reports required by Executive Order 11246, as amended, Section 503 of the Rehabilitation Act of 1973, as amended, and by rules, regulations, and orders of the Secretary of Labor, or pursuant thereto. The Contractor shall permit access to its books, records, and accounts by the Secretary of Labor for purposes of investigation to ascertain compliance with such rules, regulations, and orders.
- (h) In the event of a determination that the Contractor is not in compliance with this clause or any rule, regulation, or order of the Secretary of Labor, this contract may be canceled, terminated, or suspended in whole or in part, and the Contractor may be declared ineligible for further Government contracts, or Federally assisted construction contracts under the procedures authorized in Executive Order 11246, as amended. In addition, sanctions may be imposed and remedies invoked against the Contractor as provided in Executive Order 11246, as amended, the rules, regulations, and orders of the Secretary of Labor, or as otherwise provided by law.
- (i) The Contractor shall include the terms and conditions of this clause in every subcontract or purchase order unless exempted by the rules, regulations, or orders of the Secretary of Labor issued under Executive Order 11246, as amended, so that these terms and conditions will be binding upon each subcontractor or vendor. The Contractor shall take such action with respect to any subcontract or purchase order as the Secretary of Housing and Urban Development or the Secretary of Labor may direct as a means of enforcing such provisions, including sanctions for noncompliance; provided that if the Contractor becomes involved in, or is threatened with, litigation with a subcontractor or vendor as a result of such direction, the Contractor may request the United States to enter into the litigation to protect the interests of the United States.
- (j) Compliance with the requirements of this clause shall be to the maximum extent consistent with, but not in derogation of, compliance with section 7(b) of the Indian Self-Determination and Education Assistance Act and the Indian Preference clause of this contract.
- 40. Employment, Training, and Contracting Opportunities for Low-Income Persons, Section 3 of the Housing and Urban Development Act of 1968.**
- (a) The work to be performed under this contract is subject to the requirements of section 3 of the Housing and Urban Development Act of 1968, as amended, 12 U.S.C. 1701u (section 3). The purpose of section 3 is to ensure that employment and other economic opportunities generated by HUD assistance or HUD-assisted projects covered by section 3, shall, to the greatest extent feasible, be directed to low- and very low-income persons, particularly persons who are recipients of HUD assistance for housing.
- (b) The parties to this contract agree to comply with HUD's regulations in 24 CFR Part 135, which implement section 3. As evidenced by their execution of this contract, the parties to this contract certify that they are under no contractual or other impediment that would prevent them from complying with the Part 135 regulations.
- (c) The contractor agrees to send to each labor organization or representative of workers with which the contractor has a collective bargaining agreement or other understanding, if any, a notice advising the labor organization or workers' representative of the contractor's commitments under this section 3 clause, and will post copies of the notice in conspicuous places at the work site where both employees and applicants for training and employment positions can see the notice. The notice shall describe the section 3 preference, shall set forth minimum number and job titles subject to hire, availability of apprenticeship and training positions, the qualifications for each; and the name and location of the person(s) taking applications for each of the positions; and the anticipated date the work shall begin.
- (d) The contractor agrees to include this section 3 clause in every subcontract subject to compliance with regulations in 24 CFR Part 135, and agrees to take appropriate action, as provided in an applicable provision of the subcontract or in this section 3 clause, upon a finding that the subcontractor is in violation of the regulations in 24 CFR Part 135. The contractor will not subcontract with any subcontractor where the contractor has notice or knowledge that the subcontractor has been found in violation of the regulations in 24 CFR Part 135.
- (e) The contractor will certify that any vacant employment positions, including training positions, that are filled (1) after the contractor is selected but before the contract is executed, and (2) with persons other than those to whom the regulations of 24 CFR Part 135 require employment opportunities to be directed, were not filled to circumvent the contractor's obligations under 24 CFR Part 135.
- (f) Noncompliance with HUD's regulations in 24 CFR Part 135 may result in sanctions, termination of this contract for default, and debarment or suspension from future HUD assisted contracts.
- (g) With respect to work performed in connection with section 3 covered Indian housing assistance, section 7(b) of the Indian Self-Determination and Education Assistance Act (25 U.S.C. 450e) also applies to the work to be performed under this contract. Section 7(b) requires that to the greatest extent feasible (i) preference and opportunities for training and employment shall be given to Indians, and (ii) preference in the award of contracts and subcontracts shall be given to Indian organizations and Indian-owned Economic Enterprises. Parties to this contract that are subject to the provisions of section 3 and section 7(b) agree to comply with section 3 to the maximum extent feasible, but not in derogation of compliance with section 7(b).

#### 41. Interest of Members of Congress

No member or delegate to the Congress of the United States of America shall be admitted to any share or part of this contract or to any benefit that may arise therefrom.

#### 42. Interest of Members, Officers, or Employees and Former Members, Officers, or Employees

No member, officer, or employee of the PHA, no member of the governing body of the locality in which the project is situated, no member of the governing body of the locality in which the PHA was activated, and no other public official of such locality or localities who exercises any functions or responsibilities with respect to the project, shall, during his or her tenure, or for one year thereafter, have any interest, direct or indirect, in this contract or the proceeds thereof.

#### 43. Limitations on Payments made to Influence Certain Federal Financial Transactions

- (a) The Contractor agrees to comply with Section 1352 of Title 31, United States Code which prohibits the use of Federal appropriated funds to pay any person for influencing or attempting to influence an officer or employee of any agency, a Member of Congress, and officer or employee of Congress, or an employee of a Member of Congress in connection with any of the following covered Federal actions: the awarding of any Federal contract; the making of any Federal grant; the making of any Federal loan; the entering into of any cooperative agreement; or the modification of any Federal contract, grant, loan, or cooperative agreement.
- (b) The Contractor further agrees to comply with the requirement of the Act to furnish a disclosure (OMB Standard Form L.L.L., Disclosure of Lobbying Activities) if any funds other than Federal appropriated funds (including profit or fee received under a covered Federal transaction) have been paid, or will be paid, to any person for influencing or attempting to influence an officer or employee of any agency, a Member of Congress, an officer or employee of Congress, or an employee of a Member of Congress in connection with a Federal contract, grant, loan, or cooperative agreement.

#### 44. Royalties and Patents

The Contractor shall pay all royalties and license fees. It shall defend all suits or claims for infringement of any patent rights and shall save the PHA harmless from loss on account thereof; except that the PHA shall be responsible for all such loss when a particular design, process or the product of a particular manufacturer or manufacturers is specified and the Contractor has no reason to believe that the specified design, process, or product is an infringement. If, however, the Contractor has reason to believe that any design, process or product specified is an infringement of a patent, the Contractor shall promptly notify the Contracting Officer. Failure to give such notice shall make the Contractor responsible for resultant loss.

#### 45. Examination and Retention of Contractor's Records

be posted at all times by the Contractor and its

- (a) The PHA, HUD, or Comptroller General of the United States, or any of their duly authorized representatives shall, until 3 years after final payment under this contract, have access to and the right to examine any of the Contractor's directly pertinent books, documents, papers, or other records involving transactions related to this contract for the purpose of making audit, examination, excerpts, and transcriptions.
- (b) The Contractor agrees to include in first-tier subcontracts under this contract a clause substantially the same as paragraph (a) above. "Subcontract," as used in this clause, excludes purchase orders not exceeding \$10,000.
- (c) The periods of access and examination in paragraphs (a) and (b) above for records relating to (1) appeals under the Disputes clause of this contract, (2) litigation or settlement of claims arising from the performance of this contract, or (3) costs and expenses of this contract to which the PHA, HUD, or Comptroller General or any of their duly authorized representatives has taken exception shall continue until disposition of such appeals, litigation, claims, or exceptions.

#### 46. Labor Standards - Davis-Bacon and Related Acts

If the total amount of this contract exceeds \$2,000, the Federal labor standards set forth in the clause below shall apply to the development or construction work to be performed under the contract.

- (a) Minimum Wages.
  - (1) All laborers and mechanics employed under this contract in the development or construction of the project(s) involved will be paid unconditionally and not less often than once a week, and without subsequent deduction or rebate on any account (except such payroll deductions as are permitted by regulations issued by the Secretary of Labor under the Copeland Act (29 CFR Part 3)), the full amount of wages and bona fide fringe benefits (or cash equivalents thereof) due at time of payment computed at rates not less than those contained in the wage determination of the Secretary of Labor which is attached hereto and made a part hereof, regardless of any contractual relationship which may be alleged to exist between the Contractor and such laborers and mechanics. Contributions made or costs reasonably anticipated for bona fide fringe benefits under Section 1(b)(2) of the Davis-Bacon Act on behalf of laborers or mechanics are considered wages paid to such laborers or mechanics, subject to the provisions of 29 CFR 5.5(a)(1)(iv); also, regular contributions made or costs incurred for more than a weekly period (but not less often than quarterly) under plans, funds, or programs which cover the regular weekly period, are deemed to be constructively made or incurred during such weekly period. Such laborers and mechanics shall be paid the appropriate wage rate and fringe benefits in the wage determination for the classification of work actually performed, without regard to skill, except as provided in 29 CFR 5.5(a)(4). Laborers or mechanics performing work in more than one classification may be compensated at the rate specified for each classification for the time actually worked therein; provided, that the employer's payroll records accurately set forth the time spent in each classification in which work is performed. The wage determination (including any additional classification and wage rates conformed under 29 CFR 5.5(a)(1)(ii) and the Davis-Bacon poster (WH-1321) shall subcontractors at the site of the work in a prominent and

accessible place where it can be easily seen by the workers.

- (2) (i) Any class of laborers or mechanics, including helpers, which is not listed in the wage determination and which is to be employed under the contract shall be classified in conformance with the wage determination. HUD shall approve an additional classification and wage rate and fringe benefits therefor only when all the following criteria have been met: (A) The work to be performed by the classification requested is not performed by a classification in the wage determination; and (B) The classification is utilized in the area by the construction industry; and (C) The proposed wage rate, including any bona fide fringe benefits, bears a reasonable relationship to the wage rates contained in the wage determination.
- (ii) If the Contractor and the laborers and mechanics to be employed in the classification (if known), or their representatives, and HUD or its designee agree on the classification and wage rate (including the amount designated for fringe benefits where appropriate), a report of the action taken shall be sent by HUD or its designee to the Administrator of the Wage and Hour Division, Employee Standards Administration, U.S. Department of Labor, Washington, DC 20210. The Administrator, or an authorized representative, will approve, modify, or disapprove every additional classification action within 30 days of receipt and so advise HUD or its designee or will notify HUD or its designee within the 30-day period that additional time is necessary.
- (iii) In the event the Contractor, the laborers or mechanics to be employed in the classification or their representatives, and HUD or its designee do not agree on the proposed classification and wage rate (including the amount designated for fringe benefits, where appropriate), HUD or its designee shall refer the questions, including the views of all interested parties and the recommendation of HUD or its designee, to the Administrator of the Wage and Hour Division for determination. The Administrator, or an authorized representative, will issue a determination within 30 days of receipt and so advise HUD or its designee or will notify HUD or its designee within the 30-day period that additional time is necessary.
- (iv) The wage rate (including fringe benefits where appropriate) determined pursuant to subparagraphs (a)(2)(ii) or (iii) of this clause shall be paid to all workers performing work in the classification under this contract from the first day on which work is performed in classification.
- (3) Whenever the minimum wage rate prescribed in the contract for a class of laborers or mechanics includes a fringe benefit which is not expressed as an hourly rate, the Contractor shall either pay the benefit as stated in the wage determination or shall pay another bona fide fringe benefit or an hourly cash equivalent thereof.
- (4) If the Contractor does not make payments to a trustee or other third person, the Contractor may consider as part of the wages of any laborer or mechanic the amount of any costs reasonably anticipated in providing bona fide fringe benefits under a plan or

program; provided, that the Secretary of Labor has found, upon the written request of the Contractor, that the applicable standards of the Davis-Bacon Act have been met. The Secretary of Labor may require the Contractor to set aside in a separate account assets for the meeting of obligations under the plan or program.

- (b) Withholding of funds. HUD or its designee shall, upon its own action or upon written request of an authorized representative of the Department of Labor, withhold or cause to be withheld from the Contractor under this contract or any other Federal contract with the same prime Contractor, or any other Federally-assisted contract subject to Davis-Bacon prevailing wage requirements, which is held by the same prime Contractor, so much of the accrued payments or advances as may be considered necessary to pay laborers and mechanics, including apprentices, trainees, and helpers, employed by the Contractor or any subcontractor the full amount of wages required by the contract. In the event of failure to pay any laborer or mechanic, including any apprentice, trainee, or helper, employed or working in the construction or development of the project, all or part of the wages required by the contract, HUD or its designee may, after written notice to the Contractor, take such action as may be necessary to cause the suspension of any further payment, advance, or guarantee of funds until such violations have ceased. HUD or its designee may, after written notice to the Contractor, disburse such amounts withheld for and on account of the Contractor or subcontractor to the respective employees to whom they are due.
- (c) Payrolls and basic records.
- (1) Payrolls and basic records relating thereto shall be maintained by the Contractor during the course of the work and preserved for a period of three years thereafter for all laborers and mechanics working in the construction or development of the project. Such records shall contain the name, address, and social security number of each such worker, his or her correct classification, hourly rates of wages paid (including rates of contributions or costs anticipated for bona fide fringe benefits or cash equivalents thereof of the types described in section 1(b)(2)(B) of the Davis-Bacon Act), daily and weekly number of hours worked, deductions made, and actual wages paid. Whenever the Secretary of Labor has found, under 29 CFR 5.5(a)(1)(iv), that the wages of any laborer or mechanic include the amount of costs reasonably anticipated in providing benefits under a plan or program described in section 1(b)(2)(B) of the Davis-Bacon Act, the Contractor shall maintain records which show that the commitment to provide such benefits is enforceable, that the plan or program is financially responsible, and that the plan or program has been communicated in writing to the laborers or mechanics affected, and records which show the costs anticipated or the actual cost incurred in providing such benefits. Contractors employing apprentices or trainees under approved programs shall maintain written evidence of the registration of apprenticeship programs and certification of trainee programs, the registration of the apprentices and trainees, and the ratios and wage rates prescribed in the applicable programs.

- (2) (i) The Contractor shall submit weekly for each week in which any contract work is performed a copy of all payrolls to the Contracting Officer for transmission to HUD or its designee. The payrolls submitted shall set out accurately and completely all of the information required to be maintained under subparagraph (c)(1) of this clause. This information may be submitted in any form desired. Optional Form WH-347 (Federal Stock Number 029-005-00014-1) is available for this purpose and may be purchased from the Superintendent of Documents, U.S. Government Printing Office, Washington, D.C. 20402. The Contractor is responsible for the submission of copies of payrolls by all subcontractors. (Approved by the Office of Management and Budget under OMB Control Number 1214-0149.)
- (ii) Each payroll submitted shall be accompanied by a "Statement of Compliance," signed by the Contractor or subcontractor or his or her agent who pays or supervises the payment of the persons employed under the contract and shall certify the following:
- (A) That the payroll for the payroll period contains the information required to be maintained under paragraph (c) (1) of this clause and that such information is correct and complete;
- (B) That each laborer or mechanic (including each helper, apprentice, and trainee) employed on the contract during the payroll period has been paid the full weekly wages earned, without rebate, either directly or indirectly, and that no deductions have been made either directly or indirectly from the full wages earned, other than permissible deductions as set forth in 29 CFR Part 3; and
- (C) That each laborer or mechanic has been paid not less than the applicable wage rates and fringe benefits or cash equivalents for the classification of work performed, as specified in the applicable wage determination incorporated into the contract.
- (iii) The weekly submission of a properly executed certification set forth on the reverse side of Optional Form WH-347 shall satisfy the requirements for submission of the "Statement of Compliance" required by subparagraph (c)(2)(ii) of this clause.
- (iv) The falsification of any of the above certifications may subject the Contractor or subcontractor to civil or criminal prosecution under Section 1001 of Title 18 and Section 3729 of Title 31 of the United States Code.
- (3) The Contractor or subcontractor shall make the records required under subparagraph (c)(1) available for inspection, copying, or transcription by authorized representatives of HUD or its designee, the Contracting Officer, or the Department of Labor and shall permit such representatives to interview employees during working hours on the job. If the Contractor or subcontractor fails to submit the required records or to make them available, HUD or its designee may, after written notice to the Contractor, take such action as may be necessary to cause the suspension of any further payment, advance, or guarantee of funds. Furthermore, failure to submit the required records upon request or to

- make such records available may be grounds for debarment action pursuant to 29 CFR 5.12.
- (d) (1) Apprentices. Apprentices will be permitted to work at less than the predetermined rate for the work they performed when they are employed pursuant to and individually registered in a bona fide apprenticeship program registered with the U.S. Department of Labor, Employment and Training Administration, Office of Apprenticeship and Training, Employer and Labor Services (OATELS), or with a State Apprenticeship Agency recognized by OATELS, or if a person is employed in his or her first 90 days of probationary employment as an apprentice in such an apprenticeship program, who is not individually registered in the program, but who has been certified by OATELS or a State Apprenticeship Agency (where appropriate) to be eligible for probationary employment as an apprentice. The allowable ratio of apprentices to journeymen on the job site in any craft classification shall not be greater than the ratio permitted to the Contractor as to the entire work force under the registered program. Any worker listed on a payroll at an apprentice wage rate, who is not registered or otherwise employed as stated in this paragraph, shall be paid not less than the applicable wage rate on the wage determination for the classification of work actually performed. In addition, any apprentice performing work on the job site in excess of the ratio permitted under the registered program shall be paid not less than the applicable wage rate on the wage determination for the work actually performed. Where a contractor is performing construction on a project in a locality other than that in which its program is registered, the ratios and wage rates (expressed in percentages of the journeyman's hourly rate) specified in the Contractor's or subcontractor's registered program shall be observed. Every apprentice must be paid at not less than the rate specified in the registered program for the apprentice's level of progress, expressed as a percentage of the journeyman hourly rate specified in the applicable wage determination. Apprentices shall be paid fringe benefits in accordance with the provisions of the apprenticeship program. If the apprenticeship program does not specify fringe benefits, apprentices must be paid the full amount of fringe benefits listed on the wage determination for the applicable classification. If the Administrator of the Wage and Hour Division determines that a different practice prevails for the applicable apprentice classification, fringes shall be paid in accordance with that determination. In the event OATELS, or a State Apprenticeship Agency recognized by OATELS, withdraws approval of an apprenticeship program, the Contractor will no longer be permitted to utilize apprentices at less than the applicable predetermined rate for the work performed until an acceptable program is approved.
- (2) Trainees. Except as provided in 29 CFR 5.16, trainees will not be permitted to work at less than the predetermined rate for the work performed unless they are employed pursuant to and individually registered in a program which has received prior approval, evidenced by formal certification by the U.S. Department of Labor, Employment and Training Administration. The ratio of trainees to journeymen on the job site shall not be greater than permitted under

the plan approved by the Employment and Training Administration. Every trainee must be paid at not less than the rate specified in the approved program for the trainee's level of progress, expressed as a percentage of the journeyman hourly rate specified in the applicable wage determination. Trainees shall be paid fringe benefits in accordance with the provisions of the trainee program. If the trainee program does not mention fringe benefits, trainees shall be paid the full amount of fringe benefits listed in the wage determination unless the Administrator of the Wage and Hour Division determines that there is an apprenticeship program associated with the corresponding journeyman wage rate in the wage determination which provides for less than full fringe benefits for apprentices. Any employee listed on the payroll at a trainee rate who is not registered and participating in a training plan approved by the Employment and Training Administration shall be paid not less than the applicable wage rate in the wage determination for the classification of work actually performed. In addition, any trainee performing work on the job site in excess of the ratio permitted under the registered program shall be paid not less than the applicable wage rate in the wage determination for the work actually performed. In the event the Employment and Training Administration withdraws approval of a training program, the Contractor will no longer be permitted to utilize trainees at less than the applicable predetermined rate for the work performed until an acceptable program is approved.

(3) Equal employment opportunity. The utilization of apprentices, trainees, and journeymen under this clause shall be in conformity with the equal employment opportunity requirements of Executive Order 11246, as amended, and 29 CFR Part 30.

(e) Compliance with Copeland Act requirements. The Contractor shall comply with the requirements of 29 CFR Part 3, which are hereby incorporated by reference in this contract.

(f) Contract termination; debarment. A breach of this contract clause may be grounds for termination of the contract and for debarment as a Contractor and a subcontractor as provided in 29 CFR 5.12.

(g) Compliance with Davis-Bacon and related Act requirements. All rulings and interpretations of the Davis-Bacon and related Acts contained in 29 CFR Parts 1, 3, and 5 are herein incorporated by reference in this contract.

(h) Disputes concerning labor standards. Disputes arising out of the labor standards provisions of this clause shall not be subject to the general disputes clause of this contract. Such disputes shall be resolved in accordance with the procedures of the Department of Labor set forth in 29 CFR Parts 5, 6, and 7. Disputes within the meaning of this clause include disputes between the Contractor (or any of its subcontractors) and the PHA, HUD, the U.S. Department of Labor, or the employees or their representatives.

(i) Certification of eligibility.

(1) By entering into this contract, the Contractor certifies that neither it (nor he or she) nor any person or firm who has an interest in the Contractor's firm is a person or firm ineligible to be awarded contracts by the United States Government by virtue of section 3(a) of the Davis-Bacon Act or 29 CFR 5.12(a)(1).

(2) No part of this contract shall be subcontracted to any person or firm ineligible for award of a United States Government contract by virtue of section 3(a) of the Davis-Bacon Act or 29 CFR 5.12(a)(1).

(3) The penalty for making false statements is prescribed in the U. S. Criminal Code, 18 U.S.C. 1001.

(j) Contract Work Hours and Safety Standards Act. As used in this paragraph, the terms "laborers" and "mechanics" include watchmen and guards.

(1) Overtime requirements. No contractor or subcontractor contracting for any part of the contract work which may require or involve the employment of laborers or mechanics, including watchmen and guards, shall require or permit any such laborer or mechanic in any workweek in which the individual is employed on such work to work in excess of 40 hours in such workweek unless such laborer or mechanic receives compensation at a rate not less than one and one-half times the basic rate of pay for all hours worked in excess of 40 hours in such workweek.

(2) Violation; liability for unpaid wages; liquidated damages. In the event of any violation of the provisions set forth in subparagraph (j)(1) of this clause, the Contractor and any subcontractor responsible therefor shall be liable for the unpaid wages. In addition, such Contractor and subcontractor shall be liable to the United States (in the case of work done under contract for the District of Columbia or a territory, to such District or to such territory), for liquidated damages. Such liquidated damages shall be computed with respect to each individual laborer or mechanic (including watchmen and guards) employed in violation of the provisions set forth in subparagraph (j)(1) of this clause, in the sum of \$10 for each calendar day on which such individual was required or permitted to work in excess of the standard workweek of 40 hours without payment of the overtime wages required by provisions set forth in subparagraph (j)(1) of this clause.

(3) Withholding for unpaid wages and liquidated damages. HUD or its designee shall upon its own action or upon written request of an authorized representative of the Department of Labor withhold or cause to be withheld, from any moneys payable on account of work performed by the Contractor or subcontractor under any such contract or any Federal contract with the same prime Contractor, or any other Federally-assisted contract subject to the Contract Work Hours and Safety Standards Act, which is held by the same prime Contractor, such sums as may be determined to be necessary to satisfy any liabilities of such Contractor or subcontractor for unpaid wages and liquidated damages as provided in the provisions set forth in subparagraph (j)(2) of this clause.

(k) Subcontracts. The Contractor or subcontractor shall insert in any subcontracts all the provisions contained in this clause, and such other clauses as HUD or its designee may by appropriate instructions require, and also a clause requiring the subcontractors to include these provisions in any lower tier subcontracts. The prime Contractor shall be responsible for the compliance by any subcontractor or lower tier subcontractor with all these provisions.

---

#### 47. Non-Federal Prevailing Wage Rates

- (a) Any prevailing wage rate (including basic hourly rate and any fringe benefits), determined under State or tribal law to be prevailing, with respect to any employee in any trade or position employed under the contract, is inapplicable to the contract and shall not be enforced against the Contractor or any subcontractor, with respect to employees engaged under the contract whenever such non-Federal prevailing wage rate exceeds: (1) The applicable wage rate determined by the Secretary of Labor pursuant to the Davis-Bacon Act (40 U.S.C. 3141 et seq.) to be prevailing in the locality with respect to such trade;
- (b) An applicable apprentice wage rate based thereon specified in an apprenticeship program registered with the U.S. Department of Labor (DOL) or a DOL-recognized State Apprenticeship Agency; or
- (c) An applicable trainee wage rate based thereon specified in a DOL-certified trainee program.

#### 48. Procurement of Recovered Materials.

- (a) In accordance with Section 6002 of the Solid Waste Disposal Act, as amended by the Resource Conservation and Recovery Act, the Contractor shall procure items designated in guidelines of the Environmental Protection Agency (EPA) at 40 CFR Part 247 that contain the highest percentage of recovered materials practicable, consistent with maintaining a satisfactory level of competition. The Contractor shall procure items designated in the EPA guidelines that contain the highest percentage of recovered materials practicable unless the Contractor determines that such items: (1) are not reasonably available in a reasonable period of time; (2) fail to meet reasonable performance standards, which shall be determined on the basis of the guidelines of the National Institute of Standards and Technology, if applicable to the item; or (3) are only available at an unreasonable price.
- (b) Paragraph (a) of this clause shall apply to items purchased under this contract where: (1) the Contractor purchases in excess of \$10,000 of the item under this contract; or (2) during the preceding Federal fiscal year, the Contractor: (i) purchased any amount of the items for use under a contract that was funded with Federal appropriations and was with a Federal agency or a State agency or agency of a political subdivision of a State; and (ii) purchased a total of in excess of \$10,000 of the item both under and outside that contract.

**Applicability**

The Project or Program to which the construction work covered by this contract pertains is being assisted by the United States of America and the following Federal Labor Standards Provisions are included in this Contract pursuant to the provisions applicable to such Federal assistance.

**A. 1. (i) Minimum Wages.** All laborers and mechanics employed or working upon the site of the work, will be paid unconditionally and not less often than once a week, and without subsequent deduction or rebate on any account (except such payroll deductions as are permitted by regulations issued by the Secretary of Labor under the Copeland Act (29 CFR Part 3), the full amount of wages and bona fide fringe benefits (or cash equivalents thereof) due at time of payment computed at rates not less than those contained in the wage determination of the Secretary of Labor which is attached hereto and made a part hereof, regardless of any contractual relationship which may be alleged to exist between the contractor and such laborers and mechanics. Contributions made or costs reasonably anticipated for bona fide fringe benefits under Section 1(b)(2) of the Davis-Bacon Act on behalf of laborers or mechanics are considered wages paid to such laborers or mechanics, subject to the provisions of 29 CFR 5.5(a)(1)(iv); also, regular contributions made or costs incurred for more than a weekly period (but not less often than quarterly) under plans, funds, or programs, which cover the particular weekly period, are deemed to be constructively made or incurred during such weekly period.

Such laborers and mechanics shall be paid the appropriate wage rate and fringe benefits on the wage determination for the classification of work actually performed, without regard to skill, except as provided in 29 CFR 5.5(a)(4). Laborers or mechanics performing work in more than one classification may be compensated at the rate specified for each classification for the time actually worked therein: Provided, That the employer's payroll records accurately set forth the time spent in each classification in which work is performed. The wage determination (including any additional classification and wage rates conformed under 29 CFR 5.5(a)(1)(ii) and the Davis-Bacon poster (WH-1321) shall be posted at all times by the contractor and its subcontractors at the site of the work in a prominent and accessible, place where it can be easily seen by the workers.

(ii) (a) Any class of laborers or mechanics which is not listed in the wage determination and which is to be employed under the contract shall be classified in conformance with the wage determination. HUD shall approve an additional classification and wage rate and fringe benefits therefor only when the following criteria have been met:

(1) The work to be performed by the classification requested is not performed by a classification in the wage determination; and

(2) The classification is utilized in the area by the construction industry; and

(3) The proposed wage rate, including any bona fide fringe benefits, bears a reasonable relationship to the wage rates contained in the wage determination.

(b) If the contractor and the laborers and mechanics to be employed in the classification (if known), or their representatives, and HUD or its designee agree on the classification and wage rate (including the amount designated for fringe benefits where appropriate), a report of the action taken shall be sent by HUD or its designee to the Administrator of the Wage and Hour Division, Employment Standards Administration, U.S. Department of Labor, Washington, D.C. 20210. The Administrator, or an authorized representative, will approve, modify, or disapprove every additional classification action within 30 days of receipt and so advise HUD or its designee or will notify HUD or its designee within the 30-day period that additional time is necessary. (Approved by the Office of Management and Budget under OMB control number 1215-0140.)

(c) In the event the contractor, the laborers or mechanics to be employed in the classification or their representatives, and HUD or its designee do not agree on the proposed classification and wage rate (including the amount designated for fringe benefits, where appropriate), HUD or its designee shall refer the questions, including the views of all interested parties and the recommendation of HUD or its designee, to the Administrator for determination. The Administrator, or an authorized representative, will issue a determination within 30 days of receipt and so advise HUD or its designee or will notify HUD or its designee within the 30-day period that additional time is necessary. (Approved by the Office of Management and Budget under OMB Control Number 1215-0140.)

(d) The wage rate (including fringe benefits where appropriate) determined pursuant to subparagraphs (1)(ii)(b) or (c) of this paragraph, shall be paid to all workers performing work in the classification under this contract from the first day on which work is performed in the classification.

(iii) Whenever the minimum wage rate prescribed in the contract for a class of laborers or mechanics includes a fringe benefit which is not expressed as an hourly rate, the contractor shall either pay the benefit as stated in the wage determination or shall pay another bona fide fringe benefit or an hourly cash equivalent thereof.

(iv) If the contractor does not make payments to a trustee or other third person, the contractor may consider as part

of the wages of any laborer or mechanic the amount of any costs reasonably anticipated in providing bona fide fringe benefits under a plan or program, Provided, That the Secretary of Labor has found, upon the written request of the contractor, that the applicable standards of the Davis-Bacon Act have been met. The Secretary of Labor may require the contractor to set aside in a separate account assets for the meeting of obligations under the plan or program. (Approved by the Office of Management and Budget under OMB Control Number 1215-0140.)

**2. Withholding.** HUD or its designee shall upon its own action or upon written request of an authorized representative of the Department of Labor withhold or cause to be withheld from the contractor under this contract or any other Federal contract with the same prime contractor, or any other Federally-assisted contract subject to Davis-Bacon prevailing wage requirements, which is held by the same prime contractor so much of the accrued payments or advances as may be considered necessary to pay laborers and mechanics, including apprentices, trainees and helpers, employed by the contractor or any subcontractor the full amount of wages required by the contract in the event of failure to pay any laborer or mechanic, including any apprentice, trainee or helper, employed or working on the site of the work, all or part of the wages required by the contract, HUD or its designee may, after written notice to the contractor, sponsor, applicant, or owner, take such action as may be necessary to cause the suspension of any further payment, advance, or guarantee of funds until such violations have ceased. HUD or its designee may, after written notice to the contractor, disburse such amounts withheld for and on account of the contractor or subcontractor to the respective employees to whom they are due. The Comptroller General shall make such disbursements in the case of direct Davis-Bacon Act contracts.

**3. (I) Payrolls and basic records.** Payrolls and basic records relating thereto shall be maintained by the contractor during the course of the work preserved for a period of three years thereafter for all laborers and mechanics working at the site of the work. Such records shall contain the name, address, and social security number of each such worker, his or her correct classification, hourly rates of wages paid (including rates of contributions or costs anticipated for bona fide fringe benefits or cash equivalents thereof of the types described in Section 1(b)(2)(B) of the Davis-bacon Act), daily and weekly number of hours worked, deductions made and actual wages paid. Whenever the Secretary of Labor has found under 29 CFR 5.5 (a)(1)(iv) that the wages of any laborer or mechanic include the amount of any costs reasonably anticipated in providing benefits under a plan or program described in Section 1(b)(2)(B) of the Davis-Bacon Act, the contractor shall maintain records which show that the commitment to provide such benefits is enforceable, that the plan or program is financially responsible, and that the plan or program has been

communicated in writing to the laborers or mechanics affected, and records which show the costs anticipated or the actual cost incurred in providing such benefits. Contractors employing apprentices or trainees under approved programs shall maintain written evidence of the registration of apprenticeship programs and certification of trainee programs, the registration of the apprentices and trainees, and the ratios and wage rates prescribed in the applicable programs. (Approved by the Office of Management and Budget under OMB Control Numbers 1215-0140 and 1215-0017.)

(ii) (a) The contractor shall submit weekly for each week in which any contract work is performed a copy of all payrolls to HUD or its designee if the agency is a party to the contract, but if the agency is not such a party, the contractor will submit the payrolls to the applicant sponsor, or owner, as the case may be, for transmission to HUD or its designee. The payrolls submitted shall set out accurately and completely all of the information required to be maintained under 29 CFR 5.5(a)(3)(i) except that full social security numbers and home addresses shall not be included on weekly transmittals. Instead the payrolls shall only need to include an individually identifying number for each employee (e.g., the last four digits of the employee's social security number). The required weekly payroll information may be submitted in any form desired. Optional Form WH-347 is available for this purpose from the Wage and Hour Division Web site at <http://www.dol.gov/esa/whd/forms/wh347instr.htm> or its successor site. The prime contractor is responsible for the submission of copies of payrolls by all subcontractors. Contractors and subcontractors shall maintain the full social security number and current address of each covered worker, and shall provide them upon request to HUD or its designee if the agency is a party to the contract, but if the agency is not such a party, the contractor will submit the payrolls to the applicant sponsor, or owner, as the case may be, for transmission to HUD or its designee, the contractor, or the Wage and Hour Division of the Department of Labor for purposes of an investigation or audit of compliance with prevailing wage requirements. It is not a violation of this subparagraph for a prime contractor to require a subcontractor to provide addresses and social security numbers to the prime contractor for its own records, without weekly submission to HUD or its designee. (Approved by the Office of Management and Budget under OMB Control Number 1215-0149.)

(b) Each payroll submitted shall be accompanied by a "Statement of Compliance," signed by the contractor or subcontractor or his or her agent who pays or supervises the payment of the persons employed under the contract and shall certify the following:

(1) That the payroll for the payroll period contains the information required to be provided under 29 CFR 5.5 (a)(3)(ii), the appropriate information is being maintained under 29 CFR 5.5(a)(3)(i), and that such information is correct and complete;

(2) That each laborer or mechanic (including each helper, apprentice, and trainee) employed on the contract during the payroll period has been paid the full weekly wages earned, without rebate, either directly or indirectly, and that no deductions have been made either directly or indirectly from the full wages earned, other than permissible deductions as set forth in 29 CFR Part 3;

(3) That each laborer or mechanic has been paid not less than the applicable wage rates and fringe benefits or cash equivalents for the classification of work performed, as specified in the applicable wage determination incorporated into the contract.

(c) The weekly submission of a properly executed certification set forth on the reverse side of Optional Form WH-347 shall satisfy the requirement for submission of the "Statement of Compliance" required by subparagraph A.3.(ii)(b).

(d) The falsification of any of the above certifications may subject the contractor or subcontractor to civil or criminal prosecution under Section 1001 of Title 18 and Section 231 of Title 31 of the United States Code.

(iii) The contractor or subcontractor shall make the records required under subparagraph A.3.(i) available for inspection, copying, or transcription by authorized representatives of HUD or its designee or the Department of Labor, and shall permit such representatives to interview employees during working hours on the job. If the contractor or subcontractor fails to submit the required records or to make them available, HUD or its designee may, after written notice to the contractor, sponsor, applicant or owner, take such action as may be necessary to cause the suspension of any further payment, advance, or guarantee of funds. Furthermore, failure to submit the required records upon request or to make such records available may be grounds for debarment action pursuant to 29 CFR 5.12.

#### 4. Apprentices and Trainees.

(i) **Apprentices.** Apprentices will be permitted to work at less than the predetermined rate for the work they performed when they are employed pursuant to and individually registered in a bona fide apprenticeship program registered with the U.S. Department of Labor, Employment and Training Administration, Office of Apprenticeship Training, Employer and Labor Services, or with a State Apprenticeship Agency recognized by the Office, or if a person is employed in his or her first 90 days of probationary employment as an apprentice in such an apprenticeship program, who is not individually registered in the program, but who has been certified by the Office of Apprenticeship Training, Employer and Labor Services or a State Apprenticeship Agency (where appropriate) to be eligible for probationary employment as an apprentice. The allowable ratio of apprentices to journeymen on the job site in any craft classification shall not be greater than the ratio permitted to the contractor as to the entire work force under the registered program. Any worker listed on a payroll at an apprentice wage rate, who

is not registered or otherwise employed as stated above, shall be paid not less than the applicable wage rate on the wage determination for the classification of work actually performed. In addition, any apprentice performing work on the job site in excess of the ratio permitted under the registered program shall be paid not less than the applicable wage rate on the wage determination for the work actually performed. Where a contractor is performing construction on a project in a locality other than that in which its program is registered, the ratios and wage rates (expressed in percentages of the journeyman's hourly rate) specified in the contractor's or subcontractor's registered program shall be observed. Every apprentice must be paid at not less than the rate specified in the registered program for the apprentice's level of progress, expressed as a percentage of the journeymen hourly rate specified in the applicable wage determination. Apprentices shall be paid fringe benefits in accordance with the provisions of the apprenticeship program. If the apprenticeship program does not specify fringe benefits, apprentices must be paid the full amount of fringe benefits listed on the wage determination for the applicable classification. If the Administrator determines that a different practice prevails for the applicable apprentice classification, fringes shall be paid in accordance with that determination. In the event the Office of Apprenticeship Training, Employer and Labor Services, or a State Apprenticeship Agency recognized by the Office, withdraws approval of an apprenticeship program, the contractor will no longer be permitted to utilize apprentices at less than the applicable predetermined rate for the work performed until an acceptable program is approved.

(ii) **Trainees.** Except as provided in 29 CFR 5.16, trainees will not be permitted to work at less than the predetermined rate for the work performed unless they are employed pursuant to and individually registered in a program which has received prior approval, evidenced by formal certification by the U.S. Department of Labor, Employment and Training Administration. The ratio of trainees to journeymen on the job site shall not be greater than permitted under the plan approved by the Employment and Training Administration. Every trainee must be paid at not less than the rate specified in the approved program for the trainee's level of progress, expressed as a percentage of the journeyman hourly rate specified in the applicable wage determination. Trainees shall be paid fringe benefits in accordance with the provisions of the trainee program. If the trainee program does not mention fringe benefits, trainees shall be paid the full amount of fringe benefits listed on the wage determination unless the Administrator of the Wage and Hour Division determines that there is an apprenticeship program associated with the corresponding journeyman wage rate on the wage determination which provides for less than full fringe benefits for apprentices. Any employee listed on the payroll at a trainee rate who is not registered and participating in a training plan approved by

the Employment and Training Administration shall be paid not less than the applicable wage rate on the wage determination for the work actually performed. In addition, any trainee performing work on the job site in excess of the ratio permitted under the registered program shall be paid not less than the applicable wage rate on the wage determination for the work actually performed. In the event the Employment and Training Administration withdraws approval of a training program, the contractor will no longer be permitted to utilize trainees at less than the applicable predetermined rate for the work performed until an acceptable program is approved.

(iii) **Equal employment opportunity.** The utilization of apprentices, trainees and journeymen under 29 CFR Part 5 shall be in conformity with the equal employment opportunity requirements of Executive Order 11246, as amended, and 29 CFR Part 30.

**5. Compliance with Copeland Act requirements.** The contractor shall comply with the requirements of 29 CFR Part 3 which are incorporated by reference in this contract

**6. Subcontracts.** The contractor or subcontractor will insert in any subcontracts the clauses contained in subparagraphs 1 through 11 in this paragraph A and such other clauses as HUD or its designee may by appropriate instructions require, and a copy of the applicable prevailing wage decision, and also a clause requiring the subcontractors to include these clauses in any lower tier subcontracts. The prime contractor shall be responsible for the compliance by any subcontractor or lower tier subcontractor with all the contract clauses in this paragraph.

**7. Contract termination; debarment.** A breach of the contract clauses in 29 CFR 5.5 may be grounds for termination of the contract and for debarment as a contractor and a subcontractor as provided in 29 CFR 5.12.

**8. Compliance with Davis-Bacon and Related Act Requirements.** All rulings and interpretations of the Davis-Bacon and Related Acts contained in 29 CFR Parts 1, 3, and 5 are herein incorporated by reference in this contract

**9. Disputes concerning labor standards.** Disputes arising out of the labor standards provisions of this contract shall not be subject to the general disputes clause of this contract. Such disputes shall be resolved in accordance with the procedures of the Department of Labor set forth in 29 CFR Parts 5, 6, and 7. Disputes within the meaning of this clause include disputes between the contractor (or any of its subcontractors) and HUD or its designee, the U.S. Department of Labor, or the employees or their representatives.

**10. (I) Certification of Eligibility.** By entering into this contract the contractor certifies that neither it (nor he or she) nor any person or firm who has an interest in the contractor's firm is a person or firm ineligible to be awarded Government contracts by virtue of Section 3(a) of the Davis-Bacon Act or 29 CFR 5.12(a)(1) or to be

awarded HUD contracts or participate in HUD programs pursuant to 24 CFR Part 24.

(II) No part of this contract shall be subcontracted to any person or firm ineligible for award of a Government contract by virtue of Section 3(a) of the Davis-Bacon Act or 29 CFR 5.12(a)(1) or to be awarded HUD contracts or participate in HUD programs pursuant to 24 CFR Part 24.

(III) The penalty for making false statements is prescribed in the U.S. Criminal Code, 18 U.S.C. 1001. Additionally, U.S. Criminal Code, Section 1010, Title 18, U.S.C., "Federal Housing Administration transactions", provides in part: "Whoever, for the purpose of . . . influencing in any way the action of such Administration . . . makes, utters or publishes any statement knowing the same to be false . . . shall be fined not more than \$5,000 or imprisoned not more than two years, or both."

**11. Complaints, Proceedings, or Testimony by Employees.** No laborer or mechanic to whom the wage, salary, or other labor standards provisions of this Contract are applicable shall be discharged or in any other manner discriminated against by the Contractor or any subcontractor because such employee has filed any complaint or instituted or caused to be instituted any proceeding or has testified or is about to testify in any proceeding under or relating to the labor standards applicable under this Contract to his employer.

**B. Contract Work Hours and Safety Standards Act.** The provisions of this paragraph B are applicable where the amount of the prime contract exceeds \$100,000. As used in this paragraph, the terms "laborers" and "mechanics" include watchmen and guards.

(1) **Overtime requirements.** No contractor or subcontractor contracting for any part of the contract work which may require or involve the employment of laborers or mechanics shall require or permit any such laborer or mechanic in any workweek in which the individual is employed on such work to work in excess of 40 hours in such workweek unless such laborer or mechanic receives compensation at a rate not less than one and one-half times the basic rate of pay for all hours worked in excess of 40 hours in such workweek.

(2) **Violation; liability for unpaid wages; liquidated damages.** In the event of any violation of the clause set forth in subparagraph (1) of this paragraph, the contractor and any subcontractor responsible therefor shall be liable for the unpaid wages. In addition, such contractor and subcontractor shall be liable to the United States (in the case of work done under contract for the District of Columbia or a territory, to such District or to such territory), for liquidated damages. Such liquidated damages shall be computed with respect to each individual laborer or mechanic, including watchmen and guards, employed in violation of the clause set forth in subparagraph (1) of this paragraph, in the sum of \$10 for each calendar day on which such individual was required or permitted to work in excess of the standard workweek of 40 hours without payment of the overtime wages required by the clause set forth in subparagraph (1) of this paragraph.

---

**(3) Withholding for unpaid wages and liquidated damages.** HUD or its designee shall upon its own action or upon written request of an authorized representative of the Department of Labor withhold or cause to be withheld, from any moneys payable on account of work performed by the contractor or subcontractor under any such contract or any other Federal contract with the same prime contract, or any other Federally-assisted contract subject to the Contract Work Hours and Safety Standards Act which is held by the same prime contractor such sums as may be determined to be necessary to satisfy any liabilities of such contractor or subcontractor for unpaid wages and liquidated damages as provided in the clause set forth in subparagraph (2) of this paragraph.

**(4) Subcontracts.** The contractor or subcontractor shall insert in any subcontracts the clauses set forth in subparagraph (1) through (4) of this paragraph and also a clause requiring the subcontractors to include these clauses in any lower tier subcontracts. The prime contractor shall be responsible for compliance by any subcontractor or lower tier subcontractor with the clauses set forth in subparagraphs (1) through (4) of this paragraph.

**C. Health and Safety.** The provisions of this paragraph C are applicable where the amount of the prime contract exceeds \$100,000.

**(1)** No laborer or mechanic shall be required to work in surroundings or under working conditions which are unsanitary, hazardous, or dangerous to his health and safety as determined under construction safety and health standards promulgated by the Secretary of Labor by regulation.

**(2)** The Contractor shall comply with all regulations issued by the Secretary of Labor pursuant to Title 29 Part 1926 and failure to comply may result in imposition of sanctions pursuant to the Contract Work Hours and Safety Standards Act, (Public Law 91-54, 83 Stat 96). 40 USC 3701 et seq.

**(3)** The contractor shall include the provisions of this paragraph in every subcontract so that such provisions will be binding on each subcontractor. The contractor shall take such action with respect to any subcontractor as the Secretary of Housing and Urban Development or the Secretary of Labor shall direct as a means of enforcing such provisions.

## BIDDER QUALIFICATIONS

**Firm Name:** \_\_\_\_\_

(Company Name)

\_\_\_\_\_  
(Address)

\_\_\_\_\_  
(City, State, Zip Code)

\_\_\_\_\_  
(Phone Number)

\_\_\_\_\_  
(Fax Number)

\_\_\_\_\_  
(E-mail)

Date:

**Construction Capabilities:** (Check all that apply)

General Contracting

Electrical

Plumbing

HVAC

Demolition

Earthmoving

Asbestos Abatement

Other:

**For Corporations Only:**

Federal ID Number: \_\_\_\_\_

Name of State(s) in which incorporated:

Date(s) of incorporation: \_\_\_\_\_

If not incorporated in Missouri:

4. Attach Certificate of Authority to do Business in Missouri

5. Certificate Number: \_\_\_\_\_ Date: \_\_\_\_\_

\_\_\_\_\_  
(President's Name)

\_\_\_\_\_  
(Vice-President's Name)

\_\_\_\_\_  
(Secretary's Name)

\_\_\_\_\_  
(Treasurer's Name)

**For Partnerships Only:**

Date of Organization: \_\_\_\_\_

Type of Partnership:

General

Limited

Association

Names and Addresses of all partners: (use additional sheet if necessary)

1.

(Name)

(Address)

(City, State, Zip Code)

2.

(Name)

(Address)

(City, State, Zip Code)

**General Information:**

Federal ID Number: \_\_\_\_\_

or SSN: \_\_\_\_\_

Percent of work done by Contractor: \_\_\_\_\_

Number of Permanent Employees: \_\_\_\_\_

Number of years in business: \_\_\_\_\_

CDBG Administrative Manual  
Contract Management

Geographical limits of operation: \_\_\_\_\_

If you have done business under a different name, please give name and location:  
\_\_\_\_\_

Has firm ever failed to complete a project or defaulted on a contract? If so, state where and why:  
\_\_\_\_\_

Date: Dated this \_\_\_\_\_ day of \_\_\_\_\_, 20\_\_\_\_.

Signatures: |

Individual       Partnership       Joint Venture       Corporation

Business Name: \_\_\_\_\_

Address: \_\_\_\_\_

Telephone: \_\_\_\_\_

Fax Number: \_\_\_\_\_

Federal ID Number: \_\_\_\_\_

Social Security Number: \_\_\_\_\_

Incorporated under the laws of the State of:

(If a corporation organized in a state other than Missouri, attach certificate of Authority to do business in the State of Missouri.)

\_\_\_\_\_  
(Bidder's Signature)

\_\_\_\_\_  
(Corporate Secretary's Signature and Seal)

\_\_\_\_\_  
(Typed or Printed Name of Signor)

\_\_\_\_\_  
(Seal)

\_\_\_\_\_  
(Partner/Joint Venture Signature)

\_\_\_\_\_  
(Typed or Printed Name of Signor)

MBE  WBE  Section 3

Subcontractor \_\_\_\_\_

Address \_\_\_\_\_

Bid Amount \_\_\_\_\_

Trade or Supplier \_\_\_\_\_

Bid Accepted:  Yes  No If No, explain \_\_\_\_\_

**Section 3: Hiring of Additional Workers**

I will be hiring additional workers to complete this activity.

I will *not* be hiring additional workers to complete this activity.

Listed below are the Section 3 employment opportunities which are herein incorporated and made part of the contract's bid documentation. If new positions will be filled, please complete:

Occupation	Needed	To Be Hired	Apprentices*	Trainees*
Carpenters	_____	_____	_____	_____
Electricians	_____	_____	_____	_____
Power Equipment Operations	_____	_____	_____	_____
Ironworkers	_____	_____	_____	_____
Laborers	_____	_____	_____	_____
Plumbers/Pipefitters	_____	_____	_____	_____
Masons	_____	_____	_____	_____
Other: _____	_____	_____	_____	_____
Other: _____	_____	_____	_____	_____

\*Attach copies of program and apprentice certifications by the Missouri or U.S. Bureaus of Apprenticeship and Training.

**Certification**

In Witness Thereof, Contractor has executed his certificate this \_\_\_\_\_ day of \_\_\_\_\_, 20\_\_\_\_.

Contractor Name \_\_\_\_\_

Federal ID \_\_\_\_\_

DUNS \_\_\_\_\_

Signature of Authorized Agent \_\_\_\_\_

Printed Name \_\_\_\_\_

Date \_\_\_\_\_

## PERFORMANCE BOND

KNOW ALL PERSONS BY THESE PRESENTS: that

\_\_\_\_\_  
(Name of Contractor)

\_\_\_\_\_  
(Address of Contractor)

a \_\_\_\_\_, hereinafter called Principal, and  
(Corporation, Partnership or Individual)

\_\_\_\_\_  
(Name of Surety)

\_\_\_\_\_  
(Address of Surety) hereinafter

called Surety, are held and firmly bound unto

\_\_\_\_\_  
(Name of Owner)

\_\_\_\_\_  
(Address of Owner)

hereinafter called OWNER in the total aggregate penal sum of \_\_\_\_\_

Dollars (\$ \_\_\_\_\_ ) in lawful money of the United States, for the payment of which sum well and truly to be made, we bind ourselves, our heirs, executors, administrators, successors and assigns, jointly and severally, firmly by these presents.

THE CONDITION OF THIS OBLIGATION is such that whereas, the Principal entered into a certain CONTRACT with the OWNER, dated the \_\_\_\_\_ day of \_\_\_\_\_ 20\_\_\_\_, a copy of which is hereto attached and made a part hereof for the construction of:

NOW, THEREFORE if the Principal shall well, truly and faithfully perform its duties, all the undertakings, covenants, terms, conditions and agreements of said CONTRACT during the original term thereof, and any extensions thereof which may be granted by the OWNER with or without notice to the SURETY and during the one year guaranty period and if the PRINCIPAL shall satisfy all claims and demands incurred under such CONTRACT, and shall fully indemnify and save harmless the OWNER from all costs and damages which it may suffer by reason of failure to do so, and shall reimburse and repay the OWNER all outlay and expense which the OWNER may incur in making good any default, then this obligation shall be void, otherwise to remain in full force and effect.

CDBG Administrative Manual  
Contract Management

PROVIDED, FURTHER, that the said SURETY, for value received hereby stipulates and agrees that no change, extension of time, alteration or addition to the terms of the CONTRACT or to WORK to be performed thereunder or the SPECIFICATIONS accompanying same shall in any way affect its obligation on this BOND, and it does hereby waive notice of any such change, extension of time, alteration or addition to the terms of the CONTRACT or to the WORK or to the SPECIFICATIONS.

PROVIDED, FURTHER, that it is expressly agreed that the BOND shall be deemed amended automatically and immediately, without formal and separate amendments hereto, upon amendment to the CONTRACT not increasing the CONTRACT price more than 20 percent, so as to bind the PRINCIPAL and the SURETY to the full and faithful performance of the CONTRACT as so amended. The term "Amendment", wherever used in this BOND, and whether referring to this BOND, the CONTRACT or the Loan Documents shall include any alteration, addition, extension, or modification of any character whatsoever.

PROVIDED, FURTHER that no final settlement between the OWNER and the PRINCIPAL shall abridge the right of the other beneficiary hereunder, whose claim may be unsatisfied. The OWNER are the only beneficiaries hereunder.

IN WITNESS WHEREOF, this instrument is executed in \_\_\_\_\_ counterparts, each one of which  
(Number)

shall be deemed an original, this the \_\_\_\_\_ day of \_\_\_\_\_

ATTEST

Principal

(Principal) Secretary

(SEAL)

By

(Witness as to Principal)

(Address)

(Address)

Surety

CDBG Administrative Manual  
Contract Management

ATTEST

_____	BY _____
Witness to Surety	Attorney-in-Fact
_____	_____
(Address)	(Address)

**NOTE:** Date of BOND must not be prior to date of CONTRACT.

**If CONTRACTOR is partnership, all partners should execute BOND.**

**IMPORTANT:** Surety companies executing BONDS must appear on the Treasury Department's most current list (Circular 570 as amended) and be authorized to transact business in the state where the project is located.

**PAYMENT BOND**

KNOW ALL PERSONS BY THESE PRESENTS: that

\_\_\_\_\_ (Name of Contractor)

\_\_\_\_\_ (Address of Contractor)

a, hereinafter called Principal, and (Corporation, Partnership or Individual)

\_\_\_\_\_ (Name of Surety)

hereinafter called Surety, are held and firmly bound unto

\_\_\_\_\_ (Name of Owner)

\_\_\_\_\_ (Address of Owner)

hereinafter called OWNER, and unto all persons, firms and corporations who or which may furnish labor, or who furnish materials to perform as described under the CONTRACT and to their successors and assigns in the total aggregate penal sum of \_\_\_\_\_

Dollars (\$ \_\_\_\_\_) in lawful money of the United States, for the payment of which sum well and truly to be made, we bind ourselves, our heirs, executors, administrators, successors, and assigns, jointly and severally, firmly by these presents.

THE CONDITION OF THIS OBLIGATION is such that whereas, the PRINCIPAL entered into a certain CONTRACT with the OWNER, dated the \_\_\_\_\_ day of \_\_\_\_\_ 20\_\_\_\_\_, a copy of which is hereto attached and made a part hereof for the construction of:

NOW, THEREFORE, if the PRINCIPAL shall promptly make payment to all persons, firms and corporations furnishing materials for or performing labor in the prosecution of the WORK provided for in such CONTRACT, and any authorized extensions or modification thereof, including all amounts due for materials, lubricants, oil, gasoline, coal, repairs on machinery, equipment and tools, consumed or used in connection with the construction of such WORK and for all labor cost incurred in such WORK including that by a SUBCONTRACTOR, and to any mechanic or materialman lienholder whether it acquires its lien by operation of State or Federal law; then this obligation shall be void, otherwise to remain in full force and effect.

PROVIDED, that beneficiaries or claimants hereunder shall be limited to the SUBCONTRACTORS, and persons, firms, and corporations having a direct contract with the PRINCIPAL or its SUBCONTRACTORS.

CDBG Administrative Manual  
Contract Management

PROVIDED, FURTHER, that the said SURETY for value received hereby stipulates and agrees that no change, extension of time, alteration or addition to the terms of the CONTRACT or to the WORK to be performed thereunder or the SPECIFICATIONS accompanying the same shall in any way affect its obligation on this BOND, and it does hereby waive notice of any such change, extension of time, alteration or addition to the terms of this CONTRACT or to the WORK or to the SPECIFICATIONS.

PROVIDE, FURTHER, that no suit or action shall be commenced hereunder by any claimant: (a) Unless claimant, other than one having a direct CONTRACT with the PRINCIPAL (or with the GOVERNMENT in the event the GOVERNMENT is performing the obligations of the OWNER), shall have given written notice to any two of the following: the PRINCIPAL, the OWNER, or the SURETY above named within ninety (90) days after such claimant did or performed the last of the WORK or labor, or furnished the last of the materials for which said claim is made, stating with substantial accuracy the amount claimed and the name of the party to whom the materials were furnished, or for whom the WORK or labor was done or performed. Such notice shall be served by mailing the same by registered mail or certified mail, postage prepaid, in an envelope addressed to the PRINCIPAL, OWNER, or SURETY, at any place where an office is regularly maintained for the transaction of business, or served in any manner in which legal process may be served in the state in which the aforesaid project is located, save that such service need not be made by a public officer. (b) After the expiration of one (1) year following the date of which PRINCIPAL ceased WORK on said CONTRACT, is being understood, however, that if any limitation embodied in the BOND is prohibited by law controlling the construction hereof, such limitation shall be deemed to be amended so as to be equal to the minimum period of limitation permitted by such law.

PROVIDED, FURTHER, that it is expressly agreed that this BOND shall be deemed amended automatically and immediately, without formal and separate amendments hereto, upon amendment to the CONTRACT not increasing the CONTRACT price more than 20 percent, so as to bind the PRINCIPAL and the SURETY to the full and faithful performance of the CONTRACT as so amended. The term "Amendment", wherever used in this BOND and whether referring to this BOND, the CONTRACT or the loan Documents shall include any alteration, addition, extension or modification of any character whatsoever.

PROVIDED, FURTHER, that no final settlement between the OWNER or GOVERNMENT and the CONTRACTOR shall abridge the right of any beneficiary hereunder, whose claim may be unsatisfied.

IN WITNESS WHEREOF, this instrument is executed in \_\_\_\_\_ counterparts, each one of which  
(Number)

shall be deemed an original, this the \_\_\_\_\_ day of \_\_\_\_\_

ATTEST:

\_\_\_\_\_  
Principal

CDBG Administrative Manual  
Contract Management

(Principal) Secretary

(SEAL)

By

(Witness as to Principal)

(Address)

(Address)

Surety

ATTEST:

BY

Witness to Surety

Attorney-in-Fact

(Address)

(Address)

**NOTE: Date of BOND must not be prior to date of CONTRACT**

**If CONTRACTOR is partnership, all partners should execute BOND. IMPORTANT: Surety companies executing BONDS must appear on the Treasury Department's most current list (Circular 570 as amended) and be authorized to transact business in the State where the Project is located.**



**IFB No. 2018-10 Kitchen & Bathroom Renovation  
Project at Cottage City**

Dated: July 11, 2018

**Bid Form**

Date: \_\_\_\_\_

From: \_\_\_\_\_

\_\_\_\_\_  
\_\_\_\_\_

To: Ho using Authority of Prince George's County

9200 Basil Court, Suite 500

Largo, Maryland 20774

I, the undersigned contractor, have reviewed IFB No. 2018-10 and understand the extent and character of the work to be completed as described.

I propose to furnish all labor, materials, and equipment necessary to accomplish the work, as listed in the above documents, for the properties located at

LOCATION 1 - Cottage City Community -4142 Bunker Hill Road, Cottage City, MD 20722  
to include ten (10) One Bedroom Units to include Four (4) Accessible units,

For the sum of \_\_\_\_\_ Dollars (\$ ).

I will commence the work within ten(10) calendar days from the date the notice to proceed is received and will complete the work within 100 calendar days after starting the work.

\_\_\_\_\_  
Company Name

\_\_\_\_\_  
Signature

\_\_\_\_\_  
Title

THIS BID MUST HAVE A BREAKDOWN OF YOUR ESTIMATE ATTACHED.

IFB No. 2018-10 Kitchen & Bathroom Renovation Project at Cottage City				
		Unit Cost	LOCATION 1	LOCATION 2
<b>DIVISIONS.</b>				
<b>DIVISION 2 - SITEWORK</b>				
<b>DIVISION 5 - METALS</b>				
5.1	Railings			
5.2	Other Steel Work			
	Medicine cabinet w/Mirror Allowance : \$200.00 ea			
	Medicine cabinet w/Mirror Tilt (ADA) Allowance : \$200.00 ea			
<b>DIVISION 6 - WOOD &amp; PLASTIC</b>				
6.1	Millwork Allowance : \$			
6.2	Installation Kitchen Cabinets & Tops			
	Installation Kitchen Cabinets & Tops (ADA)			
6.3	Bathroom Vanity & Tops Allowance : \$ 500.00			
	Sink only (ADA)			
6.4	Rough Carpentry			
	Required blocking for Grab Bars			
	WINGITS Mfr #: RC-RESGBW35-2			
6.5	Finish Carpentry			
	1x12 wood shelving and cleats			
<b>DIVISION 7 - THERMAL &amp; MOISTURE</b>				
7.3	Caulking & Sealants			
<b>DIVISION 8 - DOORS &amp; WINDOWS</b>				
8.1	Exterior doors, Frames & Hardware			
8.2	Interior Doors, Frames & Hardware			
	Masonite Prehung Hollow Core 6-Panel Int. Door 30-in x 80-in w/Privacy lockset : <b>BEDROOM</b>			
	Masonite Prehung Hollow Core 6-Panel Int. Door 36-in x 80-in w/Privacy lockset : <b>BATHROOM</b> 504 Unit			
	<b>Closet Doors</b>			
	4- (Primed) Solid Core 6-Panel Slab Interior Door 30-in x 80			
	2-(Primed) Solid Core 6-Panel Slab Interior Door 36-in x 80			
	1- (Primed) Full Louver Pine Bi-Fold Closet Int. Door 24-in x 80			



	Allowance : \$ 30.00 LF			
	Wood painted 1x 12 shelving with cleats			
	<b>DIVISION 11 - EQUIPMENT</b>			
11.1	Appliances Installation ENERGY STAR RATING		HA	HA
	Refrigerator Allowance : \$ 550.00 ea		H	H
	Electric range Allowance : \$ 550.00ea		H	H
	Garbage Disposal Allowance : \$ 110.00 ea		H	H
	Exhaust fan		H	H
	Range Hood		H	H
	<b>DIVISION 15 - MECHANICAL</b>			
15.1	Plumbing Work			
	Kitchen Sink and faucet Allowance : Elkay 22-in x 25-in Stainless Single-Basin Drop-In Kitchen Sink Model # K125223 Three Hole - 6" Depth - 22 Gauge - Center Drain - Satin Finish - Sound Deadening Bottom - Integrated Mounting System - Standard 3-1/2" Drain  BRASS CRAFT CRI9C ANLE STOPS, SI- 20A BRAIDED STAINLESS SSTEEL SUPPLIES AND 649SS ESCUTCHEONS, KEENEY 461XF-6 CAST BRASS TRAP			
	Kitchen Sink offset ADA and faucet Aspen® 25W x 22"L ADA Single Bowl Stainless Steel Sink - Three Hole - 6" Depth - 21 Gauge - Rear Right Drain - Satin Finish - Integrated Mounting System - ADA Compliant - Sound Deadening Bottom - Standard 3-1/2" Drain - Mfg #GE125213  -BRASS CRAFT CRI9C ANLE STOPS, SI- 20A BRAIDED STAINLESS SSTEEL SUPPLIES AND 649SS ESCUTCHEONS, KEENEY 461XF-6 CAST BRASS TRAP			
	Vanity with Drop-in Sink and Faucet : <b>BOWL INTEGRAL PART OF COUNTERTOPW/CABINET</b>			
	Seasons® Wall Hung Lavatory Sink White China Manufacturer Part Number 13-0010ADA White China Wall Hung Lavatory - 17-3/8 x 19-1/8" - 4" Centers - Front Overflow ADA			
	Bath tub replace Bootz® Enameled Steel Bathtub - Right-Handed Drain - Self- Leveling For Easy Install - White - 5' Standard Design - 60W x			

30D x 14-1/4"H - Mfg #011-2364			
Watco® 1-Hole Overflow Plate Bath Waste Half-Kit Push-Pull Schedule 40 PVC CP			
Shower Fixtures Allowance : Delta® Activtouch Slide Bar Hand Shower - Chrome Finish - Nine-Setting Hand Shower - Features Touch-Clean® Spray Holes - 60" - 82" Stretchable Metal Hose - 28" Wall Bar W/Adjustable Slide - Push Button Spray Selection - 2.5 GPM @ 80 PSI - Mfg #51504			
Toilet 2-piece 1.28 GPF Elong. White ADA Toilet Mansfield Alto Complete Elongated Smart Height 1.28 GPF Toilet In A Box Mansfield® Alto® 1.28 GPF Elongated Comfort Height Toilet-In-A-Box - All-In-One Kit Includes Toilet Tank, Bowl, Seat, Flange Bolts And Wax Ring - SmartHeight™ Bowl For Maximum Comfort And ADA Compliance - - Made In USA - Mfg #4137 BRASS CRAFT CRI9C ANGLE STOP, 649SS ESCUTCHEON AND S1-12DL STAINLESS STEEL BRAIDED SUPPLY CONNECTOR.			
Kitchen Faucet Delta® Foundations Core-B Single Handle Kitchen Faucet - Chrome Finish - Washerless Function - 1.8 GPM @ 60 PSI - Less Spray - Mfg #B1310LF			
Bath Faucet Delta® Foundations Core-B Single Handle Bath Faucet - Drilled For Pop-Up - Chrome Finish - Washerless Function - 1.2 GPM @ 60 PSI -Mfg #B501LF -BRASS CRAFT · CR19C ANGLE STOPS, 51-12A BRAIDED STAINLESS STEEL SUPPLIES AND 649SS ESCUTCHEONS, KEENEY 5700PC OFFSFT TYPE GRID DRAIN AND 5463XPC CAST BRASS TRA			
Plumberex Pro-Extreme™ Sink Tubular ADA Cover Under Sink Protector Fits Brass/Plastic 1-1/4" And 1-1/2" P-Traps - ADA 4.19.4 And ANSI 117.1 Compliant - Made In USA - Meets All Plumbing Codes Mfg #x4333			
HVAC			
DIVISION 16 - ELECTRICAL			
Electrical Systems			
Lighting fixtures Allowance : \$ 200.00			

<b>Fire Alarm Systems</b>			
Smoke Alarm ALL (NAPISCE PROVIDED)			
15 Amp Circuit Guard Pro Lighted GFCI - White Hubbell 15 Amp Circuit Guard® Lighted GFCI Duplex - With Wall Plate - White - Mfg #GF15WLA			
15 Amp Single Pole Wall Switch - White - Package Of 10 Mfg #336406			
120 Volt - Single Pole - Wired - Use With Copper Wire Only - 15 Amp Decorator Receptacle - White - Package of 10 Part #: 336403			
<b>DIVISION 17 - ASBESTOS AND / OR LEAD ABATEMENT</b>			
<b>Asbestos Abatement</b>			
<b>Lead Paint Abatement</b>			
<b>DIVISION 18A - ALLOWANCES</b>			
Allowance At Owners Discretion			
<b>DIVISION 18B - GENERAL CONDITIONS</b>			
General Conditions			
Final Cleaning			
Job Superintendent			
General Liability Insurance			
<b>DIVISION 18C - OVERHEAD/PROFIT &amp; PERMIT FEES</b>			
Overhead & Fees			
<b>BID- IFB No. 2018-10 Kitchen &amp; Bathroom Renovation Project at Cottage City Community</b>			
<b>TOTAL CONSTRUCTION COST Unit</b>			
<b>LOCATION 1 (5 UNITS) TOTAL CONSTRUCTION COST</b>			
<b>LOCATION 2 (5 UNITS) TOTAL CONSTRUCTION COST</b>			
<b>LOCATION 1 &amp; 2 (10 UNITS) TOTAL CONSTRUCTION COST</b>			

**Equal Employment  
Opportunity Certification**  
Excerpt From 41 CFR §60-1.4(b)

U.S. Department of Housing  
and Urban Development  
Office of Housing  
Federal Housing Commissioner

Department of Veterans Affairs  
OMB Control No. 2502-0029  
(exp. 9/30/2016)

The applicant hereby agrees that it will incorporate or cause to be incorporated into any contract for construction work, or modification thereof, as defined in the regulations of the Secretary of Labor at 41 CFR Chapter 60, which is paid for in whole or in part with funds obtained from the Federal Government or borrowed on the credit of the Federal Government pursuant to a grant, contract, loan insurance, or guarantee, or undertaken pursuant to any Federal program involving such grant, contract, loan, insurance, or guarantee, the following equal opportunity clause:

During the performance of this contract, the contractor agrees as follows:

- (1) The contractor will not discriminate against any employee or applicant for employment because of race, color, religion, sex, or national origin. The contractor will take affirmative action to ensure that applicants are employed, and that employees are treated during employment without regard to their race, color, religion, sex, or national origin, such action shall include, but not be limited to the following: Employment, upgrading, demotion, or transfer; recruitment or recruitment advertising; layoff or termination; rates of pay or other forms of compensation; and selection for training, including apprenticeship. The contractor agrees to post in conspicuous places, available to employees and applicants for employment, notices to be provided setting forth the provisions of this nondiscrimination clause.
- ) The contractor will, in all solicitations or advertisements for employees placed by or on behalf of the contractor, state that all qualified applicants will receive considerations for employment without regard to race, color, religion, sex, or national origin.
- (3) The contractor will send to each labor union or representative of workers with which it has a collective bargaining agreement or other contract or understanding, a notice to be provided advising the said labor union or workers' representatives of the contractor's commitments under this section, and shall post copies of the notice in conspicuous places available to employees and applicants for employment.
- (4) The contractor will comply with all provisions of Executive Order 11246 of September 24, 1965, and of the rules, regulations and relevant orders of the Secretary of Labor.
- (5) The contractor will furnish all information and reports required by Executive Order 11246 of September 24, 1965, and by rules, regulations, and orders of the Secretary of Labor, or pursuant thereto, and will permit access to its books, records, and accounts by the administering agency and the Secretary of Labor for purposes of investigation to ascertain compliance with such rules, regulations, and orders.

(6) In the event of the contractor's noncompliance with the nondiscrimination clauses of this contract or with any of the said rules, regulations, or orders, this contract may be canceled, terminated, or suspended in whole or in part and the contractor may be declared ineligible for further Government contracts or federally assisted construction contracts in accordance with procedures authorized in Executive Order 11246 of September 24, 1965, and such other sanctions may be imposed and remedies invoked as provided in Executive Order 11246 of September 24, 1965, or by rule, regulation, or order of the Secretary of Labor, or as otherwise provided by law.

(7) The contractor will include the portion of the sentence immediately preceding paragraph (1) and the provisions of paragraphs (1) through (7) in every subcontract or purchase order unless exempted by rules, regulations, or orders of the Secretary of Labor issued pursuant to section 204 of Executive Order 11246 of September 24, 1965, so that such provisions will be binding upon each subcontractor or vendor. The contractor will take such action with respect to any subcontract or purchase order as the administering agency may direct as a means of enforcing such provisions, including sanctions for noncompliance. **Provided, however,** That in the event a contractor becomes involved in, or is threatened with, litigation with a subcontractor or vendor as a result of such direction by the administering agency the contractor may request the United States to enter into such litigation to protect the interests of the United States.

The applicant further agrees that it will be bound by the above equal opportunity clause with respect to its own employment practices when it participates in federally assisted construction work:

**Provided,** That if the applicant so participating is a State or local government, the above equal opportunity clause is not applicable to any agency, instrumentality or subdivision of such government which does not participate in work on or under the contract.

The applicant agrees that it will assist and cooperate actively with the administering agency and the Secretary of Labor in obtaining the compliance of contractors and subcontractors with the equal opportunity clause and the rules, regulations, and relevant orders of the Secretary of Labor, that it will furnish the administering agency and the Secretary of Labor such information as they may require for the supervision of such compliance, and that it will otherwise assist the administering agency in the discharge of the agency's primary responsibility for securing compliance.

The applicant further agrees that it will refrain from entering into any contract or contract modification subject to Executive Order 11246 of September 24, 1965, with a contractor debarred from, or who has not demonstrated eligibility for, Government contracts and Federally-assisted construction contracts pursuant to the Executive order and will carry out such sanctions and penalties for violation of the equal opportunity clause as may be imposed

Firm Name and Address

By

Title

upon contractors and subcontractors by the administering agency or the Secretary of Labor pursuant to Part II, Subpart D of the Executive order. In addition, the applicant agrees that if it fails or refuses to comply with these undertakings, the administering agency may take any or all of the following actions: Cancel, terminate, or suspend in whole or in part this grant (contract, loan, insurance, guarantee); refrain from extending any further assistance to the applicant under the program with respect to which the failure or refund occurred until satisfactory assurance of future compliance has been received from such applicant; and refer the case to the Department of Justice for appropriate legal proceedings.

#### Excerpt from HUD Regulations

##### 200.410 Definition of term "applicant".

- (a) In multifamily housing transactions where controls over the mortgagor are exercised by the Commissioner either through the ownership of corporate stock or under the provisions of a regulatory agreement, the term "applicant" as used in this subpart shall mean the mortgagor.
- (b) In transactions other than those specified in paragraph (a) of this section, the term "applicant" as used in this subpart shall mean the builder, dealer or contractor performing the construction, repair or rehabilitation work for the mortgagor or other borrower.

##### 200.420 Equal Opportunity Clause to be included in contracts and subcontracts.

- (a) The following equal opportunity clause shall be included in each contract and subcontract which is not exempt:

During the performance of this contract, the contractor agrees as follows:

- (1) The contractor will not discriminate against any employee or applicant for employment because of race, creed, color, or national origin. The contractor will take affirmative action to ensure that applicants are employed, and that employees are treated during employment without regard to their race, creed, color, or national origin. Such action shall include, but not be limited to the following: employment, upgrading, demotion or transfer; recruitment or recruitment advertising; layoff or termination; rates of pay or other forms of compensation; and selection for training, including apprenticeship. The contractor agrees to post in conspicuous places, available to employees and applicants for employment, notices to be provided setting forth the provisions of the nondiscrimination clause.

- (2) The contractor will in all solicitations or advertisements for employees placed by or on behalf of the contractor, state that all qualified applicants will receive consideration for employment without regard to race, creed, color, or national origin.

- (3) The contractor will send to each labor union or representative of workers with which he has a collective bargaining agreement or other contract or understanding, a notice, to be provided, advising the said labor union or workers' representative of the contractor's commitments under this section, and shall post copies of the notices in conspicuous places available to employees and applicants for employment.

- (4) The contractor will comply with all provisions of Executive Order 10925 of March 6, 1961, as amended, and of the regulations, and relevant orders of the President's Committee on Equal Employment Opportunity created thereby.

- (5) The contractor will furnish all information and reports required by Executive Order 10925 of March 6, 1961, as amended, and by the regulations, and orders of the said Committee, or pursuant thereto, and will permit access to his books, records, and accounts by HUD and the Committee for purposes of investigation to ascertain compliance with such regulations, and orders.

- (6) In the event of the contractor's non-compliance with the nondiscrimination clause of this contract or with any of the said regulations, or orders, this contract may be cancelled, terminated or suspended in whole or in part and the contractor may be declared ineligible for further Government contracts or Federally-assisted construction contracts in accordance with procedures authorized in Executive Order 10925 of March 6, 1961, as amended, and such other sanctions may be imposed and remedies invoked provided in the said Executive Order or by regulations, or order of the President's Committee on Equal Employment Opportunity, or as otherwise provided by law.

- (7) The contractor will include the provisions of Paragraphs (1) through (7) in every subcontract or purchase order unless exempted by regulations, or orders of the President's Committee on Equal Employment Opportunity issued pursuant to Section 303 of Executive Order 10925 of March 6, 1961, as amended, so that such provisions will be binding upon each subcontractor or vendor. The contractor will take such action with respect to any subcontract or purchase orders as HUD may direct as a means of enforcing such provisions, including sanctions for noncompliance: Provided, however, that in the event the contractor becomes involved in, or is threatened with, litigation with a subcontractor or vendor as a result of such direction by HUD, the contractor may request the United States to enter into such litigation to protect the interests of the United States.

- (b) Except in subcontracts for the performance of construction work at the site of construction, the clause is not required to be inserted in subcontracts below the second tier. Subcontracts may incorporate by reference to the equal opportunity clause.

##### 200.425 Modification in and exemptions from the regulations in this subpart.

- (a) The following transactions and contracts are exempt from the regulations in this subpart:

- (1) Loans, mortgages, contracts and subcontracts not exceeding \$10,000.

- (2) Contract and subcontracts not exceeding \$100,000 for standard commercial supplies or raw material;

- (3) Contracts and subcontracts under which work is to be or has been performed outside the United States and where no recruitment of workers within the United States is involved. To the extent that work pursuant to such contracts is done within the United States, the equal opportunity clause shall be applicable;

- (4) Contracts for the sale of Government property where no appreciable amount of work is involved; and

- (5) Contracts and subcontracts for an indefinite quantity which are not to extend for more than one year if the purchaser determines that the amounts to be ordered under any such contract or subcontract are not reasonably expected to exceed \$100,000 in the case of contracts or subcontracts for standard commercial supplies and raw materials, or \$10,000 in the case of all other contracts and subcontracts.

General Decision Number: MD180058 09/28/2018 MD58

Superseded General Decision Number: MD20170058

State: Maryland

Construction Type: Building

County: Prince George's County in Maryland.

BUILDING CONSTRUCTION PROJECTS (does not include single family homes or apartments up to and including 4 stories).

Note: Under Executive Order (EO) 13658, an hourly minimum wage of \$10.35 for calendar year 2018 applies to all contracts subject to the Davis-Bacon Act for which the contract is awarded (and any solicitation was issued) on or after January 1, 2015. If this contract is covered by the EO, the contractor must pay all workers in any classification listed on this wage determination at least \$10.35 per hour (or the applicable wage rate listed on this wage determination, if it is higher) for all hours spent performing on the contract in calendar year 2018. The EO minimum wage rate will be adjusted annually. Please note that this EO applies to the above-mentioned types of contracts entered into by the federal government that are subject to the Davis-Bacon Act itself, but it does not apply to contracts subject only to the Davis-Bacon Related Acts, including those set forth at 29 CFR 5.1(a)(2)-(60). Additional information on contractor requirements and worker protections under the EO is available at [www.dol.gov/whd/govcontracts](http://www.dol.gov/whd/govcontracts).

Modification Number	Publication Date
0	01/05/2018
1	01/12/2018
2	02/09/2018
3	02/23/2018
4	03/23/2018
5	04/20/2018
6	05/04/2018
7	05/11/2018
8	05/25/2018
9	06/15/2018
10	06/29/2018
11	07/06/2018
12	07/13/2018
13	08/03/2018
14	08/17/2018
15	08/24/2018
16	09/07/2018
17	09/14/2018
18	09/21/2018
19	09/28/2018

ASBE0024-007 10/01/2017

	Rates	Fringes
ASBESTOS WORKER/HEAT & FROST INSULATOR.....	\$ 35.13	16.22

Includes the application of all insulating materials, protective coverings, coatings and finishes to all types of mechanical systems

-----  
ASBE0024-010 10/01/2017

	Rates	Fringes
--	-------	---------

ASBESTOS WORKER: HAZARDOUS  
 MATERIAL HANDLER (Removal of  
 hazardous material from  
 ceilings, floors, mechanical  
 systems, and walls).....\$ 22.81                      7.34

-----  
 BRMD0001-006 04/29/2018

	Rates	Fringes
TILE SETTER.....	\$ 28.20	11.67

-----  
 BRMD0001-011 04/29/2018

	Rates	Fringes
BRICKLAYER (Excluding Pointing, Caulking and Cleaning).....	\$ 31.36	10.78

-----  
 BRMD0001-012 04/29/2018

	Rates	Fringes
MASON - STONE.....	\$ 37.91	17.08

-----  
 BRMD0001-013 04/29/2018

	Rates	Fringes
TERRAZZO WORKER/SETTER.....	\$ 28.20	11.67

-----  
 CARP0197-001 05/01/2018

	Rates	Fringes
CARPENTER (Including Acoustical Ceiling Installation, Drywall Hanging, Metal Stud Installation and Form Work).....	\$ 28.71	12.08

-----  
 CARP0219-001 05/01/2018

	Rates	Fringes
MILLWRIGHT.....	\$ 34.24	11.23

-----  
 ELEC0026-021 09/03/2018

	Rates	Fringes
ELECTRICIAN (Communication and Sound Equipment).....	\$ 28.05	10.91

-----  
 ELEC0026-022 06/04/2018

	Rates	Fringes
ELECTRICIAN (Including low voltage wiring for and installation of alarms, HVAC controls).....	\$ 45.45	18.01+a

a. PAID HOLIDAYS: New Year's Day, Inauguration Day, Martin Luther King Jr.'s Birthday, Memorial Day, Independence Day, Labor Day, Veterans' Day, Thanksgiving Day, the day after Thanksgiving Day and Christmas Day.

-----  
 ELEV0010-001 01/01/2018

	Rates	Fringes
ELEVATOR MECHANIC.....	\$ 44.12	32.645+a+b

a. PAID HOLIDAYS: New Year's Day, Memorial Day, Independence Day, Labor Day, Veterans' Day, Thanksgiving Day, Christmas Day and the Friday after Thanksgiving.

b. VACATIONS: Employer contributes 8% of basic hourly rate for 5 years or more of service; 6% of basic hourly rate for 6 months to 5 years of service as vacation pay credit.

-----  
 ENGI0077-017 05/01/2018

	Rates	Fringes
POWER EQUIPMENT OPERATOR:		
Backhoe.....	\$ 31.50	9.20+a
Bulldozer.....	\$ 31.50	9.20+a

a. PAID HOLIDAYS: New Year's Day, Inaugural Day, Decoration Day, Independence Day, Labor Day, Martin Luther King's Birthday, Veterans' Day, Thanksgiving Day, Friday after Thanksgiving and Christmas Day.

-----  
 IRON0005-011 06/01/2017

	Rates	Fringes
IRONWORKER.....	\$ 31.15	20.63

-----  
 \* LABO0011-016 06/01/2018

	Rates	Fringes
LABORER (Common or General).....	\$ 16.56	8.32
LABORER: Mason Tender -		
Cement/Concrete.....	\$ 24.22	8.32
LABORER: Pipelayer.....	\$ 24.22	8.32

-----  
 PAIN0051-014 06/01/2018

	Rates	Fringes
GLAZIER		
Glazing Contracts \$2 million and under.....	\$ 26.07	12.15
Glazing Contracts over \$2 million.....	\$ 30.31	12.15

-----  
 PAIN0051-019 06/01/2017

	Rates	Fringes
PAINTER		
Brush, Roller, Spray and Drywall Finisher/Taper.....	\$ 25.06	9.66
Industrial.....	\$ 30.90	10.49

-----  
 PLAS0891-005 07/01/2018

	Rates	Fringes
PLASTERER.....	\$ 29.53	6.80

PLAS0891-006 02/01/2018

	Rates	Fringes
CEMENT MASON/CONCRETE FINISHER...	\$ 28.15	10.58

PLAS0891-008 08/01/2016

	Rates	Fringes
PLASTERER (Fireproofing Including Sprayer, Mixer, and Handler)		
Handler.....	\$ 16.50	4.89
Mixer/Pump.....	\$ 18.50	4.89
Sprayer.....	\$ 23.00	4.89

PLUM0005-010 08/01/2018

	Rates	Fringes
PLUMBER.....	\$ 42.92	18.15+a

a. PAID HOLIDAYS: Labor Day, Veterans' Day, Thanksgiving Day and the day after Thanksgiving, Christmas Day, New Year's Day, Martin Luther King's Birthday, Memorial Day and the Fourth of July.

PLUM0602-011 08/01/2018

	Rates	Fringes
PIPEFITTER (Including HVAC Pipe and System Installation)....	\$ 41.64	21.57+a

a. PAID HOLIDAYS: New Year's Day, Martin Luther King's Birthday, Memorial Day, Independence Day, Labor Day, Veterans' Day, Thanksgiving Day and the day after Thanksgiving and Christmas Day.

ROOF0030-016 05/01/2016

	Rates	Fringes
ROOFER.....	\$ 28.75	11.74

SFMD0669-001 04/01/2018

	Rates	Fringes
SPRINKLER FITTER (Fire Sprinklers).....	\$ 35.60	20.24

SHEE0100-015 07/01/2018

	Rates	Fringes
SHEET METAL WORKER (Including HVAC Duct Installation).....	\$ 40.27	20.34+a

a. PAID HOLIDAYS: New Year's Day, Martin Luther King's Birthday, Memorial Day, Independence Day, Labor Day, Veterans Day, Thanksgiving Day and Christmas Day

SUMD2010-092 08/04/2010

Rates	Fringes
-------	---------

LABORER		
Grade Checker.....	\$ 16.00	2.90
Landscape.....	\$ 9.23	0.00
Mason Tender - Brick.....	\$ 13.28	2.95
Mason Tender - Stone.....	\$ 14.03	0.00
Mason Tender for Pointing, Caulking and Cleaning.....	\$ 14.15	0.00
Mortar Mixer.....	\$ 16.61	9.08

POINTER, CAULKER, CLEANER,  
Includes pointing, caulking,  
cleaning of existing masonry,  
brick, stone and cement  
structures (restoration  
work); excludes pointing,  
caulking, cleaning of new or  
replacement  
masonry, brick, stone or  
cement.....\$ 19.14

POWER EQUIPMENT OPERATOR:		
Asphalt Roller.....	\$ 21.35	5.38
Bobcat/Skid Loader.....	\$ 18.05	8.78
Boom.....	\$ 21.44	8.29
Crane.....	\$ 20.95	6.18
Excavator.....	\$ 20.00	0.00
Forklift.....	\$ 16.00	5.12
Gradall.....	\$ 20.50	8.42
Grader/Blade.....	\$ 14.50	5.18
Loader.....	\$ 24.00	5.40
Paver.....	\$ 17.47	6.36
Roller excluding Asphalt....	\$ 17.60	3.88

TILE FINISHER.....\$ 17.87 7.32

TRUCK DRIVER		
Dump Truck.....	\$ 15.90	1.12
Tractor Haul Truck.....	\$ 17.87	9.98

-----  
WELDERS - Receive rate prescribed for craft performing  
operation to which welding is incidental.  
=====

Note: Executive Order (EO) 13706, Establishing Paid Sick Leave for Federal Contractors applies to all contracts subject to the Davis-Bacon Act for which the contract is awarded (and any solicitation was issued) on or after January 1, 2017. If this contract is covered by the EO, the contractor must provide employees with 1 hour of paid sick leave for every 30 hours they work, up to 56 hours of paid sick leave each year. Employees must be permitted to use paid sick leave for their own illness, injury or other health-related needs, including preventive care; to assist a family member (or person who is like family to the employee) who is ill, injured, or has other health-related needs, including preventive care; or for reasons resulting from, or to assist a family member (or person who is like family to the employee) who is a victim of, domestic violence, sexual assault, or stalking. Additional information on contractor requirements and worker protections under the EO is available at [www.dol.gov/whd/govcontracts](http://www.dol.gov/whd/govcontracts).

Unlisted classifications needed for work not included within the scope of the classifications listed may be added after award only as provided in the labor standards contract clauses (29CFR 5.5 (a) (1) (ii)).

-----

The body of each wage determination lists the classification and wage rates that have been found to be prevailing for the cited type(s) of construction in the area covered by the wage determination. The classifications are listed in alphabetical order of "identifiers" that indicate whether the particular rate is a union rate (current union negotiated rate for local), a survey rate (weighted average rate) or a union average rate (weighted union average rate).

#### Union Rate Identifiers

A four letter classification abbreviation identifier enclosed in dotted lines beginning with characters other than "SU" or "UAVG" denotes that the union classification and rate were prevailing for that classification in the survey. Example: PLUM0198-005 07/01/2014. PLUM is an abbreviation identifier of the union which prevailed in the survey for this classification, which in this example would be Plumbers. 0198 indicates the local union number or district council number where applicable, i.e., Plumbers Local 0198. The next number, 005 in the example, is an internal number used in processing the wage determination. 07/01/2014 is the effective date of the most current negotiated rate, which in this example is July 1, 2014.

Union prevailing wage rates are updated to reflect all rate changes in the collective bargaining agreement (CBA) governing this classification and rate.

#### Survey Rate Identifiers

Classifications listed under the "SU" identifier indicate that no one rate prevailed for this classification in the survey and the published rate is derived by computing a weighted average rate based on all the rates reported in the survey for that classification. As this weighted average rate includes all rates reported in the survey, it may include both union and non-union rates. Example: SULA2012-007 5/13/2014. SU indicates the rates are survey rates based on a weighted average calculation of rates and are not majority rates. LA indicates the State of Louisiana. 2012 is the year of survey on which these classifications and rates are based. The next number, 007 in the example, is an internal number used in producing the wage determination. 5/13/2014 indicates the survey completion date for the classifications and rates under that identifier.

Survey wage rates are not updated and remain in effect until a new survey is conducted.

#### Union Average Rate Identifiers

Classification(s) listed under the UAVG identifier indicate that no single majority rate prevailed for those classifications; however, 100% of the data reported for the classifications was union data. EXAMPLE: UAVG-OH-0010 08/29/2014. UAVG indicates that the rate is a weighted union average rate. OH indicates the state. The next number, 0010 in the example, is an internal number used in producing the wage determination. 08/29/2014 indicates the survey completion date for the classifications and rates under that identifier.

A UAVG rate will be updated once a year, usually in January of each year, to reflect a weighted average of the current negotiated/CBA rate of the union locals from which the rate is based.

-----  
WAGE DETERMINATION APPEALS PROCESS

1.) Has there been an initial decision in the matter? This can be:

- \* an existing published wage determination
- \* a survey underlying a wage determination
- \* a Wage and Hour Division letter setting forth a position on a wage determination matter
- \* a conformance (additional classification and rate) ruling

On survey related matters, initial contact, including requests for summaries of surveys, should be with the Wage and Hour Regional Office for the area in which the survey was conducted because those Regional Offices have responsibility for the Davis-Bacon survey program. If the response from this initial contact is not satisfactory, then the process described in 2.) and 3.) should be followed.

With regard to any other matter not yet ripe for the formal process described here, initial contact should be with the Branch of Construction Wage Determinations. Write to:

Branch of Construction Wage Determinations  
Wage and Hour Division  
U.S. Department of Labor  
200 Constitution Avenue, N.W.  
Washington, DC 20210

2.) If the answer to the question in 1.) is yes, then an interested party (those affected by the action) can request review and reconsideration from the Wage and Hour Administrator (See 29 CFR Part 1.8 and 29 CFR Part 7). Write to:

Wage and Hour Administrator  
U.S. Department of Labor  
200 Constitution Avenue, N.W.  
Washington, DC 20210

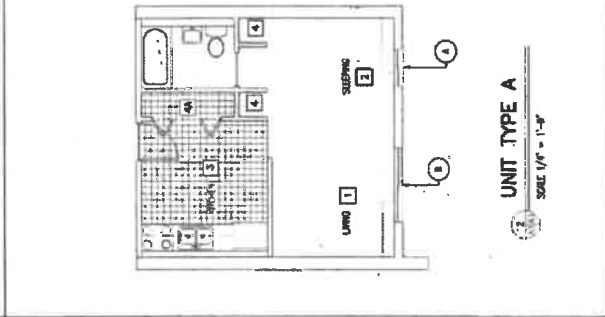
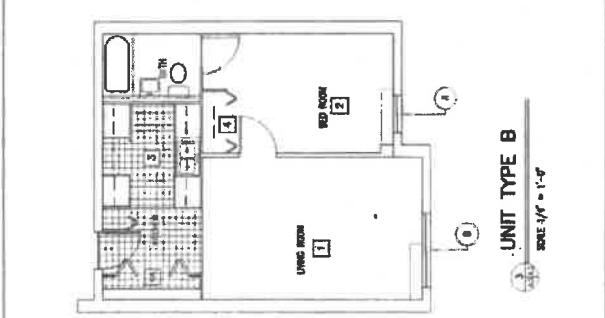
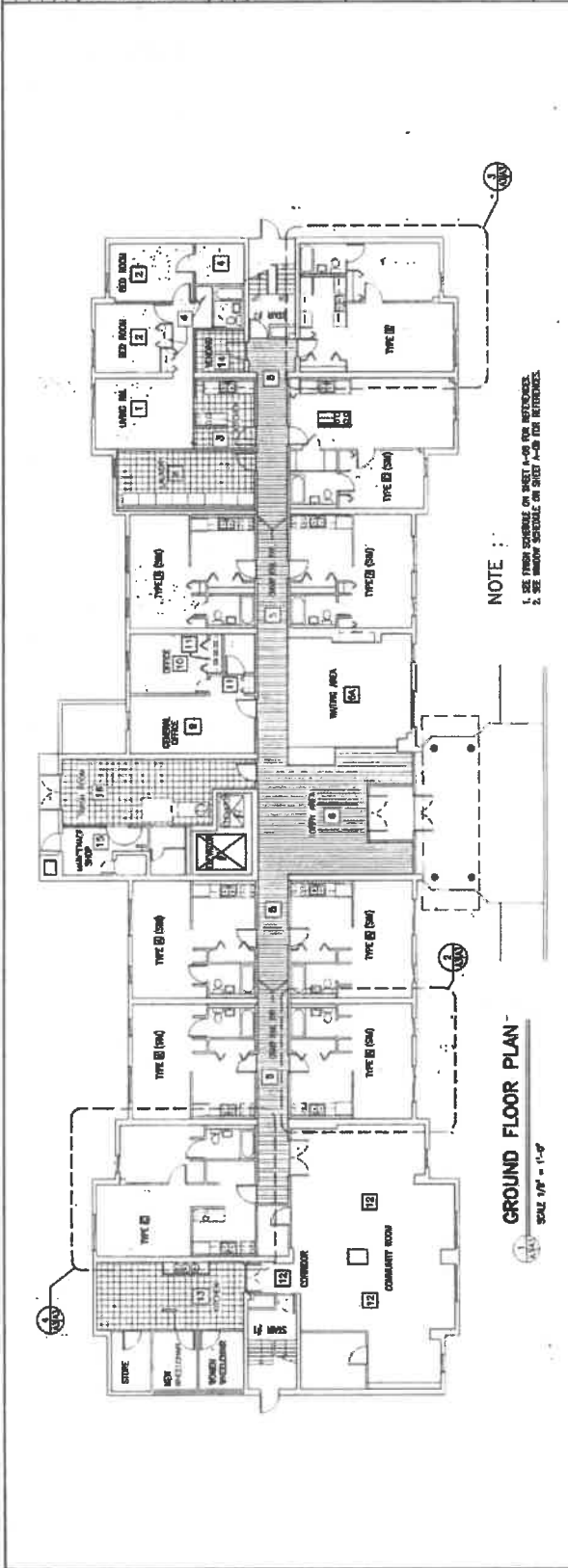
The request should be accompanied by a full statement of the interested party's position and by any information (wage payment data, project description, area practice material, etc.) that the requestor considers relevant to the issue.

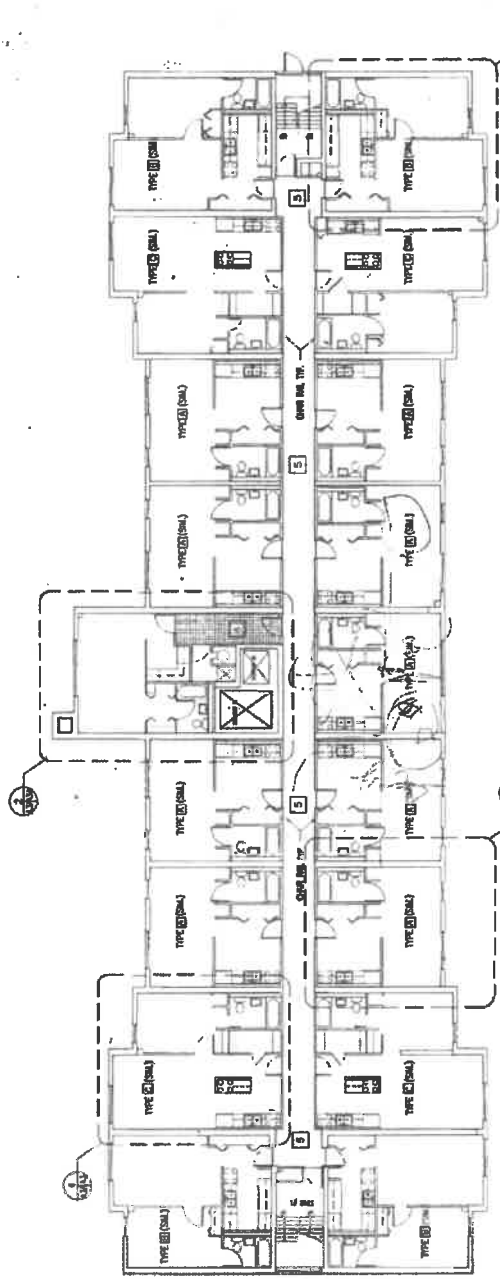
3.) If the decision of the Administrator is not favorable, an interested party may appeal directly to the Administrative Review Board (formerly the Wage Appeals Board). Write to:

Administrative Review Board  
U.S. Department of Labor  
200 Constitution Avenue, N.W.  
Washington, DC 20210

4.) All decisions by the Administrative Review Board are final.

=====  
END OF GENERAL DECISION





NOTE :

1. SEE FINISH SCHEDULE ON SHEET A-05 FOR REFERENCES.
2. SEE WINDOW SCHEDULE ON SHEET A-09 FOR REFERENCES.

**TYPICAL FLOOR PLAN**

SCALE 1/8" = 1'-0"



**UNIT TYPE D**

SCALE 1/8" = 1'-0"

THE HOUSING AUTHORITY OF PRINCE GEORGE'S COUNTY

IFB No. 2018-010 Kitchens & Bathroom Renovation Project at Cottage City

**Exhibit 1**

**SCOPE OF SERVICES**

- 1.1 The HOUSING AUTHORITY OF PRINCE GEORGE'S COUNTY is soliciting bids for the renovation/repair of ten (10) 1BR Dwelling Unit housing units. The work under this IFB shall be performed at the Cottage City Community 4142 Bunker Hill Road, Cottage City, MD 20722 and shall include furnishing all labor, material, equipment, tools, supplies, services and incidentals, and performing all work necessary for the renovation of kitchen, baths, and flooring of ten (10) residential units to include two (2) fully accessible residential units and associated improvements in strict conformance with all of the Contract documents. The work is to include the painting of each unit. All walls shall be cleaned, patched and painted. This work is being financed, in whole or in part, through grants provided by the Prince George's County Community Development Block Grant (CDBG) the Housing and Urban Development, Davis-Bacon labor standards will apply.

**GENERAL**

**1. PAINTING**

Contractor to include all materials labor and tools. Prepare and evenly apply 2 coats of paint to all walls, trim and ceiling surfaces, per specifications. Living room to have one(1) feature wall painted one of two pre-selected colors. Clean all surfaces upon completion

**2. FLOORING & BASE**

Install new LVT planks flooring over existing. Install 4" cove base .Level all floors w/latex underlayment(as needed). All necessary thresholds are to be installed. All seams invisible. All Whole boxes to remain on site.

**3. LIGHTING**

Remove existing and install new energy efficient light fixtures. Install, connect, patch, repair and paint per CDs. LED lighting to be used wherever possible.

**4. INTERIOR DOORS**

Remove existing closet doors & frames. Install new doors, framing and finish per CDs. Install new Pre-hung 6 panel hollow core doors and bi-fold doors and hardware. Install door stops at all doors and provide hardware and locksets as required. Patch, repair & paint walls & ceilings Patch, repair & paint, per specifications.

**5. SMOKE DETECTORS ( Provided by HAPGC)**

Remove existing and install new wired smoke detectors with battery backup unit. Install a additional unit in bedroom. Inter connect to existing circuit. Install, connect, patch, and repair. Paint per · CDs.

**THE HOUSING AUTHORITY OF PRINCE GEORGE'S COUNTY**

**IFB No. 2018-010 Kitchens & Bathroom Renovation Project at Cottage City**

**6. SUPPLY AND RETURN AIR REGISTERS**

**Remove existing and Provide and install new supply and return registers.**

**7. ELECTRICAL OUTLET AND SWITCH COVERS**

**Replace all existing GFCI with new. Replace all existing outlets and switches. Remove existing and install new outlet and switch covers**

**8. Horizontal Louver blinds**

**Remove all existing blinds. Provide and install new 1" slat plastic room darkening, white horizontal Louver cordless binds within all window jambs. Patch, repair & paint, per specifications.**

**KITCHEN AREAS**

**9. Owner supplied Items**

**The Owner is to supply kitchen cabinets and countertops. The Owner is to supply the following appliances: Refrigerator, electric stove and garbage disposal.**

**10. Quality and Workmanship**

**All materials and workmanship shall meet or exceed all requirements of the local plumbing and electrical codes.**

**11. WALL & BASE CABINETS & COUNTERTOPS**

**Remove existing cabinets, countertops and splashes. Install new wood wall and base cabinets, countertops and splashes. Patch, repair and paint, per CDs. The Owner is to supply kitchen cabinets and countertop.**

**12. KITCHEN SINK & FAUCET**

**Remove existing & install new single bowl sink, faucet & Accessories. Connect to existing waste, vent lines. Provide new Supply line and cut-off valves. Connect, patch, repair & paint, per specifications.**

**13. GARBAGE DISPOSALS**

**Remove existing Install new garbage disposals. Install connect, patch, and repair and paint per CDs. The Owner is to supply garbage disposal.**

**14. RANGEHOODS & RANGE OUTLETS**

**Remove existing and install new range hoods. Install over existing range outlet and install new recessed outlet behind range. Install, connect, patch, repair and paint, per specifications.**

THE HOUSING AUTHORITY OF PRINCE GEORGE'S COUNTY

IFB No. 2018-010 Kitchens & Bathroom Renovation Project at Cottage City

**BATH ROOM AREAS**

**15. CERAMIC TILE FLOORING AND TUB SURROUND**

Remove existing wall surround panels & tub liners. Install new tub. Install cement backer and 6x6 Ceramic tile and 2x2 accent tile, to tub surround (wet) area. Tile is to extend from tub rim to ceiling. The Bathroom floor is to receive 2x2 ceramic tiles. Apply one course of curved base tile around perimeter of floor. Install beveled 4" x ¾" marble threshold at door. Patch, repair & paint, per specifications.

**16. WATER CLOSET**

Remove existing and install new 2-piece 1.28 GPF HI-EFF toilet (ADA Compliant) , elongated seats, piping valves, accessories, and toilet paper dispensers. Patch, repair & paint, per specifications.

**17. SINK, FAUCETS, MEDICINE CABS & VANITIES**

Remove existing & install new sink, faucets, shower faucet, vanities, medicine cabinets light fixtures, GFI outlets, soap dish, toothbrush holders, towel rod & accessories. Water saving aerators are to be employed. Patch, repair & paint, per specifications.

**18. SAFETY GRAB BARS**

Remove existing & install new safety grab (1 ½" dia.) bars in bathroom per plan an specifications. Patch, repair & paint, per specifications. 505 Units will have additional requirements and or equipment, see detailed specifications.

**19. Bath Exhaust Vent**

Remove existing and install new bath exhaust vent. Install in existing opening. Install, connect, patch, repair and paint, per specifications

**END**

## **Cottage City Towne Modified Accessible Units**

### **Modifications Included**

#### **Bathroom Radius 60" and 36" doorway (Unit reconfigured)**

1. Install Roll-in Shower Stall w/ Grab Bars
2. Shower Wand
3. Raised Height Elongated Toilet
4. Elongated toilet set
5. Wall hung open Accessible Sink
6. ADA Shower Controls
7. ADA Faucet (Single Handle)
8. Insulated pipe drain protection
9. Tilt Mirror
10. ADA Compliant Grab Bars at toilet
11. Lever door handles

#### **Kitchen (Open space plan re-configuration)**

1. Open Sink/Pipe Drain Protection
2. ADA Compliant electric range
3. ADA Compliant Refrigerator
4. ADA offset sink
5. ADA Faucet (Single Handle)
6. Accessible Garbage Disposal Switch
7. Open Work Station 31"
8. Lowered Exhaust Hood

#### **Bedroom /general**

9. Reconfigured bedroom and bathroom access / added closet
10. Lowered closet rod(s)
11. Lever lock set
12. Large Rocker (type) light switches ADA compliant
13. Visual and Audio Smoke detector w/ battery back-up ( 2 locations )
14. Additional structural blocking and support
15. Lowered entry door peep-hole
16. Relocated Thermostat control

## **Accessible Bathroom - UFAS Compliant**

### **Notes:**

1. Remove existing grab bars if present and install new grab bars, per spec
2. Remove existing lavatory and install new lavatory
3. Install bathtub seat
4. Remove existing shower head and install new hand held shower unit
5. ~~Shower controls to be located in this area~~
6. Existing tub to remain
7. Remove existing toilet tissue holder and install new toilet tissue holder
8. Remove existing toilet and install new toilet
9. Remove existing medicine cabinet and mirror; install new medicine cabinet and mirror
10. Remove existing mirror and install new mirror
11. Remove existing towel rack and install new towel rack
12. Remove existing lavatory; install new lavatory/vanity unit
13. Remove existing medicine cabinet and install new medicine cabinet
14. Remove existing porcelain surrounds at existing tub; existing tub to remain
15. Remove existing ceramic tile floor and install new ceramic tile flooring and 6x6) Tub sur-round
16. Existing light to remain
17. Existing towel dispenser to remain
18. Remove existing soap dispenser and install new soap dispenser
19. Install blocking in existing wall to support grab bars
20. Remove existing toothbrush/tumbler holder; install new toothbrush/tumbler holder
21. Remove existing soap dish; install new soap dish
22. Insulate all exposed pipes
23. Repair existing ceramic tile as required
24. Remove existing towel dispenser and install new towel dispenser
25. Remove existing mirror and install new tilt mirror

**SCOPE OF  
SERVICES**

- 1.1 The HOUSING AUTHORITY OF PRINCE GEORGE'S COUNTY is soliciting bids for the renovation/repair of ten (10) 1BR Dwelling Unit housing units. The work under this IFB shall be performed at the Cottage City Community 4142 Bunker Hill Road, Cottage City, MD 20722 and shall include furnishing all labor, material, equipment, tools, supplies, services and incidentals, and performing all work necessary for the renovation of kitchen, baths, and flooring of ten (10) residential units to include two (4) fully accessible residential units and associated improvements in strict conformance with all of the Contract documents. The work is to include the painting of each unit. All walls shall be cleaned, patched and painted. This work is being financed, in whole or in part, through grants provided by the Prince George's County Community Development Block Grant (CDBG) the Housing and Urban Development, **Davis-Bacon labor standards** will apply.

**GENERAL**

**1. PAINTING**

Contractor to include all materials labor and tools. Prepare and evenly apply 2 coats of paint to all walls, trim and ceiling surfaces, per specifications. Living room to have one(1) feature wall painted one of two pre-selected colors. Clean all surfaces upon completion

**2. FLOORING & BASE**

Install new LVT planks flooring over existing. Install 4" cove base . Level all floors w/latex underlayment(as needed). All necessary thresholds are to be installed. All seams invisible. All Whole boxes to remain on site.

**3. LIGHTING**

Remove existing and install new energy efficient light fixtures. Install, connect, patch, repair and paint per CDs. LED lighting to be used wherever possible.

**4. INTERIOR DOORS**

Remove existing closet doors & frames. Install new doors, framing and finish per CDs. Install new Pre-hung 6 panel hollow core doors and bi-fold doors and hardware. Install door stops at all doors and provide hardware and locksets as required. Patch, repair & paint walls & ceilings Patch, repair & paint, per specifications.

**5. SMOKE DETECTORS ( Provided by HAPGC)**

Remove existing and install new wired smoke detectors with battery backup unit. Install a additional unit in bedroom. Inter connect to existing circuit. Install, connect, patch, and repair. Paint per - CDs.

**6. SUPPLY AND RETURN AIR REGISTERS**

Remove existing and Provide and install new supply and return registers.

**7. ELECTRICAL OUTLET AND SWITCH COVERS**

Replace all existing GFCI with new. Replace all existing outlets and switches. Remove existing and install new outlet and switch covers

**8. Horizontal Louver blinds**

Remove all existing blinds. Provide and install new 1" slat plastic room darkening, white horizontal Louver cordless blinds within all window jambs. Patch, repair & paint, per specifications.

**KITCHEN AREAS**

**9. Owner supplied Items**

The Owner is to supply kitchen cabinets and countertops. The Owner is to supply the following appliances: Refrigerator, electric stove and garbage disposal.

**10. Quality and Workmanship**

All materials and workmanship shall meet or exceed all requirements of the local plumbing and electrical codes.

**11. WALL & BASE CABINETS & COUNTERTOPS**

Remove existing cabinets, countertops and splashes. Install new wood wall and base cabinets, countertops and splashes. Patch, repair and paint, per CDs. The Owner is to supply kitchen cabinets and countertop.

**12. KITCHEN SINK & FAUCET**

Remove existing & install new single bowl sink, faucet & Accessories. Connect to existing waste, vent lines. Provide new Supply line and cut-off valves. Connect, patch, repair & paint, per specifications.

**13. GARBAGE DISPOSALS**

Remove existing Install new garbage disposals. Install connect, patch, and repair and paint per CDs. The Owner is to supply garbage disposal.

**14. RANGEHOODS & RANGE OUTLETS**

Remove existing and install new range hoods. Install over existing range outlet and install new recessed outlet behind range. Install, connect, patch, repair and paint, per specifications.

**BATH ROOM AREAS**

**15. CERAMIC TILE FLOORING AND TUB SURROUND**

Remove existing wall surround panels & tub liners. Install new tub. Install cement backer and 6x6 Ceramic tile and 2x2 accent tile, to tub surround (wet) area. Tile is to extend from tub rim to ceiling. The Bathroom floor is to receive 2x2 ceramic tiles. Apply one course of curved base tile around perimeter of floor. Install beveled 4" x 3/4" marble threshold at door. Patch, repair & paint, per specifications.

**16. WATER CLOSET**

Remove existing and install new 2-piece 1.28 GPF HI-EFF toilet (ADA Compliant) , elongated seats, piping valves, accessories, and toilet paper dispensers. Patch, repair & paint, per specifications.

**17. SINK, FAUCETS, MEDICINE CABS & VANITIES**

Remove existing & install new sink, faucets, shower faucet, vanities, medicine cabinets light fixtures, GFI outlets, soap dish, toothbrush holders, towel rod & accessories. Water saving aerators are to be employed. Patch, repair & paint, per specifications.

**18. SAFETY GRAB BARS**

Remove existing & install new safety grab (1 1/2" dia.) bars in bathroom per plan and specifications. Patch, repair & paint, per specifications. 505 Units will have additional requirements and or equipment, see detailed specifications.

**19. Bath Exhaust Vent**

Remove existing and install new bath exhaust vent. Install in existing opening. Install, connect, patch, repair and paint, per specifications

**END**

**USFAS Compliance Review: Unit 316 Cottage City**

**Michael Jackson , Project manager**

**NOTE:**

**1. Uniform Federal Accessibility Standards (UFAS), 24 C.F.R. § 40, Appendix A.**

**([www.access-board.gov/ufas/ufas.pdf](http://www.access-board.gov/ufas/ufas.pdf))**

**2. As it pertains to Properties owned, operated and/or managed by recipients of Federal financial assistance. See Section 504 of the Rehabilitation Act of 1973 (Section 504), 29 U.S.C. § 794; 24 C.F.R. Part 8. However, the properties may also be subject to the Fair Housing Act (42 U.S.C. §§ 3601-20; 24 C.F.R. Part 100); and/or the Americans with Disabilities Act of 1990 (42 U.S.C. §§ 12101 et seq.)**



## **1 Kitchen**

**1a** -Remove 6' open counter in kitchen to allow for required clearance of 48" at both the stove and sink  
Repair supporting wall and floor as required.

**Citation : UFAS 4.34.6.2 CLEAR FLOOR SPACE** A clear floor space at least 30 in by 48 in (760 mm by 1220 mm) complying with 4.2.4 that allows either a forward or a parallel approach by a person in a wheelchair shall be provided at all appliances in the kitchen, including the range or cooktop, oven, refrigerator/freezer, dishwasher, and trash compactor. Laundry equipment located in the kitchen shall comply with 4.34

**Citation : UFAS (4.34.6.5\* SINK.**

The sink and surrounding counter shall comply with the following requirements (see Fig. 51):1) The sink and surrounding counter shall be mounted at a maximum height of 34 in (865 mm) above the floor, measured from the floor to the top of the counter surface, or shall be adjustable or replaceable as a unit to provide alternative heights of **28 in, 32 in, and 36 in** (710 mm, 815 mm, and 915 mm), measured from the floor to the top of the counter surface or sink rim. The total width of sink and counter area shall be 30 in (760 mm).

**1B** -Install additional cabinets in configuration as shown, per plan

**1C** - Relocate Garbage Disposal switch to face of base cabinet ELECTRICAL

**1D** - Insulate exposed pipes under sink.

**Citation : UFAS 4.19.4 EXPOSED PIPES AND SURFACES.**

## **2 Living Room**

**2A** – Relocate thermostat and heat convector controls to a height of 48" ELECTRICAL

**Citation : UFAS A4.27 CONTROLS AND OPERATING MECHANISMS.**

## **3 Bedroom**

**3A** – Relocate existing wall separating bathroom and bedroom , to allow a distance of 18" clearance from centerline of toilet. Apply ½ " greenboard where appropriate ½" standard sheetrock in all other areas. Relocation of wall will result in the Demo/ retention of bifold doors(2). Steel framing of wall to incorporate 2x6 blocking centered at 36" AFF to accommodate grab bars in bathroom.green gree

**Citation : UFAS 4.16.2 CLEAR FLOOR SPACE**

Demo, retain and relocate existing 36" interior door and the construction of new closet as per plan.

3B- Install closet rod at Max 54" AFF, and a continuous shelf at a height of max. 56" AFF., within Proposed closet .

**Citation : UFAS 4.34.2 Clear Door Width is at least 32" (Measured from the door face to the opposite stop when the door is open 90°.**

**Citation : UFAS 4.25.3 HEIGHT.**

3C – relocate, reframe and install bi-fold doors at closet entry.

#### **4 Bathroom ( See, Exhibit B and C)**

**Citation : UFAS 4.22.3 CLEAR FLOOR SPACE. The accessible fixtures and controls required in 4.22.4, 4.22.5, 4.22.6, and 4.22.7 shall be on an accessible route. An unobstructed turning space complying with 4.2.3 shall be provided within an accessible toilet room. The clear floor space at fixtures and controls, the accessible route, and the turning space may overlap.**  
**4.34.5.7 CLEAR FLOOR SPACE. Clear floor space at fixtures may overlap. EXCEPTION: In bathrooms with only one water closet, one lavatory, and one bathtub or shower, a clear floor space of 30 in by 60 in (760 mm by 1525 mm) may be used in lieu of the unobstructed turning space.**

4A - Relocate existing bathroom light switch 48" AFF on sidewall of bathroom.

4B- Remove existing accessory switch and Non-compliant outlet. ELECTRICAL

4C - Construct new wall to define the hall closet space

4D - Repair and replace ceramic tile flooring, remove tile as required to complete pattern.

4E - Repair and replace vct tile flooring, remove tile as required to complete pattern.

4E - Replace and Install marble threshold. no higher than ½ "

**Citation : 404.2.5 Theshold , if provided at doorways, shall be 1/2 Inch**

4 F- Repair and patch paint all affect walls of construction area.

4G-PLUMBING Relocate shower control handle to the max. Height of 48" AFF PLUMBING

**Citation : UFAS 4.34.5.5 SHOWERS.**

4H Relocate Bathroom cabinet a usable shelf no higher than 44 in (1120 mm) above the floor.

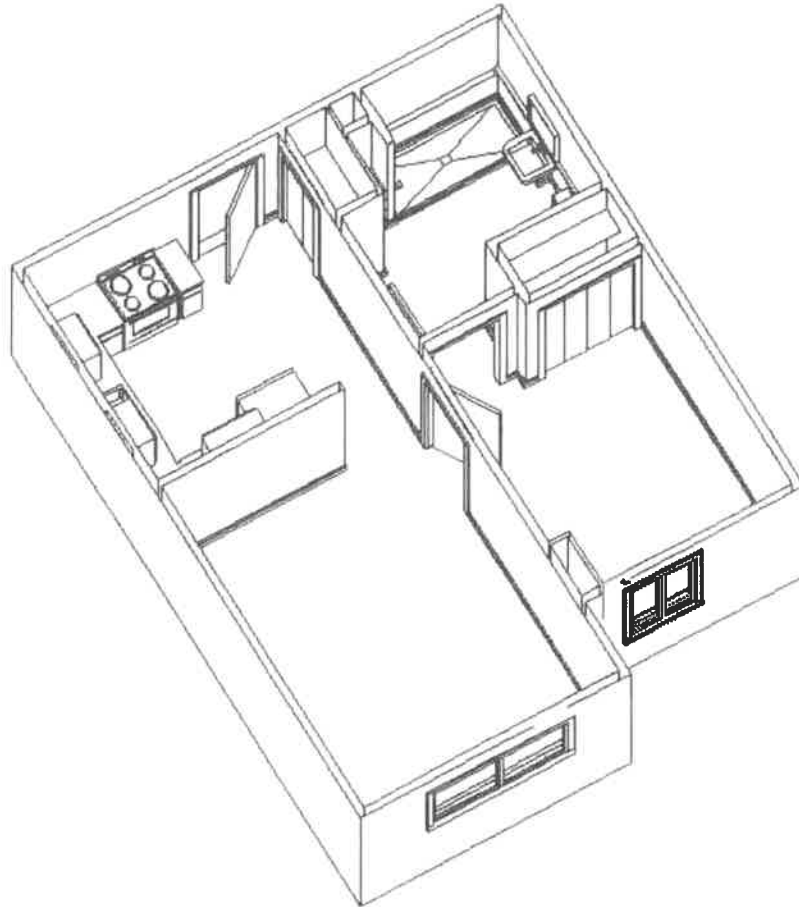
**Citation : UFAS 4.34.5.3 LAVATORY, MIRRORS, AND MEDICINE CABINETS.**

4I Insulate exposed pipes under Sink

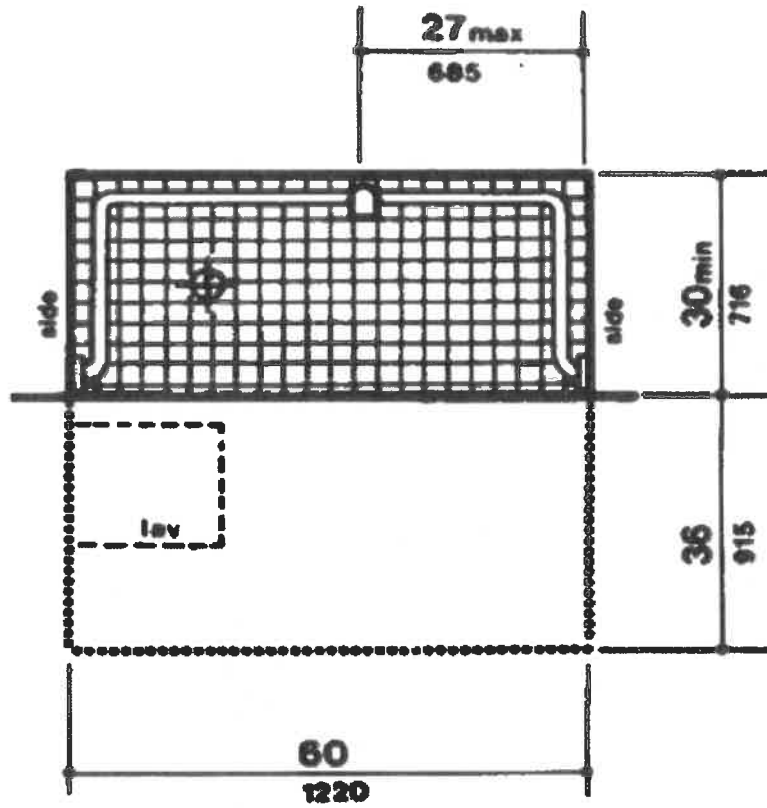
**Citation : 4.19.4 EXPOSED PIPES AND SURFACES.**

**End of Review**

**Exhibit A. Interior views**

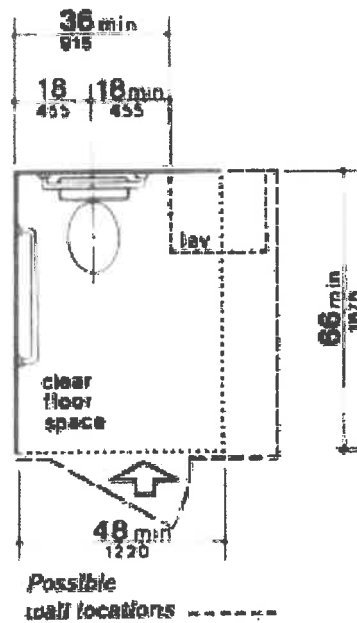
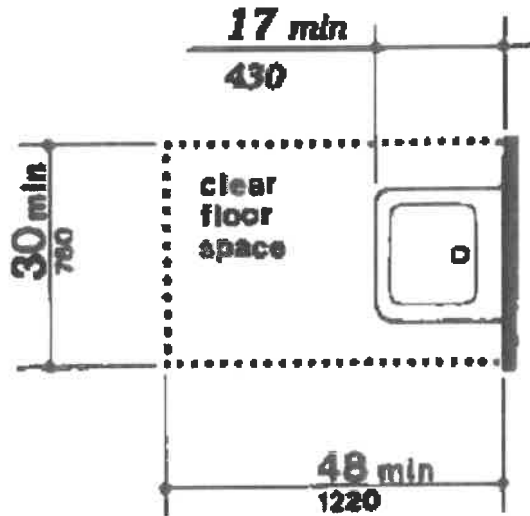


**Exhibit B. Clearances**



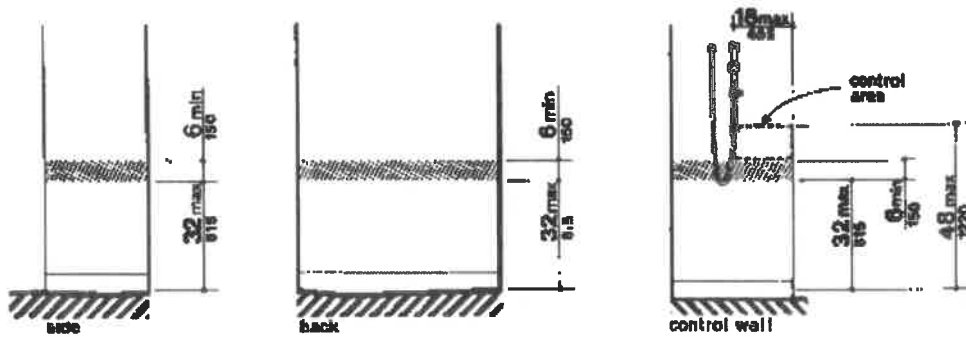
(b)  
30-in by 60-in  
(760-mm by 1525-mm) Stall

**4.19.3 CLEAR FLOOR SPACE.** A clear floor space 30 in by 48 in (760 mm by 1220 mm) complying with 4.2.4 shall be provided in front of a lavatory to allow forward approach. Such clear floor space shall adjoin or overlap an accessible route and shall extend a maximum of 19 in (485 mm) underneath the lavatory (see Fig. 32).

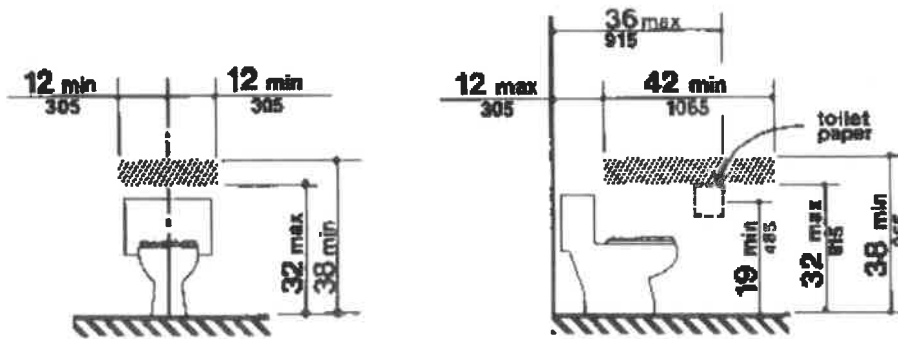


**Figure 28**  
Clear Floor Space at Water Closets

**Exhibit C. Clearances Grab bar locations**



**Figure 49(b)**  
**Location of Grab Bars and Controls**  
**of Adaptable Showers - 30-in by 60-in Stall**



**Figure 47(b)**  
**Reinforced Areas for Installation of Grab Bars**

Lighting Selection -Marlborough Towne Renovation

Room	sku	Model	Description	Cost(SRC)	Alternate
Kitchen	#1001375539	74048/HD	15 in. White LED Edge-Lit Flat Round Panel Flushmount	\$59.92	#1000010127 \$44 <sup>97</sup>
Bath	#837895	HB2050-35	Hampton Bay 3-Light Brushed Nickel Bath Bar Light	\$12 <sup>98</sup>	Fountain Buena Vista Collection 3-Light Brushed Nickel Wall Mount Vanity Light Model# 6613-BN \$13 <sup>51</sup>
Bath	#1001375553	# 74029/HD	1 ft. x 1 ft. White LED Edge-Lit Flat Panel Flushmount	\$49.92	#1000010127 \$44 <sup>97</sup>
Hall Closet	#1001224334	# 54617142	7 in. Bright White LED Ceiling Round Flushmount Easy Light with Pull Chain	\$19.97	
Bedroom	#1000010127	FMLS L 11 840 M4	Lithonia Lighting 11 in. ROUND Low-Profile White LED Flushmount	\$44 <sup>97</sup>	#1001375539
Dining Room	#1000052875	1000052875	Hampton Bay 1-Light Oil Rubbed Bronze Vintage Bulb Flushmount	\$39 <sup>00</sup>	Commercial Electric 2-Light Rustic Iron Semi-Flush Mount Light Model# ESS8212

## 74048/HD

Model # 74048-01 | Item # 42025471-0 | Store SKU # 010792110



## HB2050-35

Home > Lighting > Ceiling Fixtures > Bathroom Lighting > 3-Light > HB2050-35

Model # HB2050-35 | Item # 420222560 | Store SKU # 037895



## # 74029/HD

Model # 74029-01 | Item # 42024791-0 | Store SKU # 01079199



### Commercial Electric

## 15 in. White LED Edge-Lit Flat Round Panel Flushmount

- ENERGY STAR certified using ultra-efficient LED technology
- Lasts 45+ years using 80% less energy than conventional lighting
- Even light distribution with no flicker, glare or hot spots

**\$67<sup>29</sup>** each

Choose Your Options  
Product Description

### Hampton Bay

## 3-Light Brushed Nickel Bath Bar Light

★★★★ (95) | White & Nickel | Quonset 5-Armwork (13)

- Uses three 100-Watt bulbs
- We have an other nickel finish.com can be found in any other style
- Features recessed design

**\$12<sup>98</sup>** each

### Commercial Electric

## 1 ft. x 1 ft. White LED Edge-Lit Flat Panel Flushmount

★★★★ (288) | White & Nickel | Quonset 5-Armwork (13)

- ENERGY STAR certified using ultra-efficient LED technology
- Lasts 45+ years using 80% less energy than conventional lighting
- Even light distribution with no flicker, glare or hot spots

**\$49<sup>97</sup>** each

Choose Your Options  
Product Description

# 54617142



**Commercial Electric**

7 in. Bright White integrated A16 A19 LED Flushmount Ceiling Light Lampholder Ball Replacement Fixture

★★★★☆ (93) Write a Review

- Energy Star certified for energy efficiency
- Includes mounting hardware
- Light fixture compatible with A16 A19 LED bulbs

**\$19.97**

LET'S PROTECT THIS.

FMLS11 840 M4

Model # FMLS11 840 M4 Internet # 208212242 Store SKU # 208210982



**Lithonia Lighting**

11 in. Round Low Profile White LED Flushmount Light Fixture

★★★★☆ (47) Write a Review

- Sleek, low-profile design with modern finish
- Energy-efficient LED lighting technology
- 300 lumens 4000K Bright White compact fluorescent bulb

**\$49.97**

LET'S PROTECT THIS.

FMLS11 840 M4

Model # 100002275 Internet # 208210290 Store SKU # 100002275



**Hampton Bay**

1-light Oil Rubbed Bronze Vintage Bulb Flushmount Light Fixture



★★★★☆

- Includes 100-watt bulb
- Includes mounting hardware
- Vintage design includes Edison-style bulb

**\$40.98**

LET'S PROTECT THIS.

## **HAPGC - Renovation Product Listing and Specifications**

-  Binder1
-  DIVISION 06 - WingIts
-  DIVISION 08- Sliding Door
-  DIVISION 09 - Ceramic – Floor bath room
-  DIVISION 09 - Ceramic – Wall tile Accent
-  DIVISION 09 - Ceramic WALL
-  DIVISION 09 - Flooring Vinyl Tile -PLANK - SHAW
-  DIVISION 09 - Flooring Vinyl Tile -PLANK
-  DIVISION 09 - Marble threshold
-  DIVISION 09 - Paint \_Walls
-  DIVISION 09 - Vinyl Composite Tile
-  DIVISION 10 - Mirror Tilt
-  DIVISION 10 - Tilted mirror SS.Frame
-  DIVISION 11 - Garbage Disposal
-  DIVISION 11 -Refrigerator
-  DIVISION 11 -Stove 2 BLACK
-  DIVISION 11 -Stove
-  DIVISION 15 - BATH Faucet 1
-  DIVISION 15 - Elongated Toilet Bowl ADA
-  DIVISION 15 - Kitchen Faucet
-  DIVISION 15 - shower valve
-  DIVISION 15 - Toilet tank
-  DIVISION 15 - TubShower Trim
-  DIVISION 15 - Under Sink Protector ADA
-  DIVISION 15 -Bath tub
-  DIVISION 15 -Decorator Receptacle
-  DIVISION 15 -Elongated Toilet Seat ADA
-  DIVISION 15 -Hand Shower
-  DIVISION 15 -Kitchen Sink ADA
-  DIVISION 15 -Kitchen Sink
-  DIVISION 15 -Medical Tranfer Seat ADA
-  DIVISION 15 -refrigerator 2 BLACK
-  DIVISION 15 -refrigerator
-  DIVISION 15 -Wall Hung Lavatory ADA
-  DIVISION 16 - GFCI
-  DIVISION 16 - Smoke Alarm ADA
-  DIVISION 16 - Smoke Alarm CO2
-  DIVISION 16 - Smoke Alarm
-  DIVISION 16 -receptacle
-  DIVISION 16 -switch
-  DIVISION 16 -wall plate
-  SPEC\_01

Item:

Structural Grab Bar Wingts

DIVISION 16 - ELECTRICAL

Manufacturer #

Mfr #: RC-RESGBW35-2

Color /Finish

Blk/white

**Description**

Hollow Wall Anchor, Fire Retardant Structural Plastic, Drill Size 3/4 In., Screw Length 3-1/2 In., Screw Type Phillips, Features Waterproof, Use With Wing Its Grab Bars, Includes Steel Screw, Meets/Exceeds ADA/Commercial Building Codes, Package Quantity 2

**REQUIRED:**

Wingts Apache200 3/4 in. Drill Bit

- Drills holes through ceramic wall tile in seconds
- Engineered for cordless drills; no adapter or arbor needed
- The preferred drilling method for installing Wingts fasteners



<b>Item:</b> Prefinished Hardboard Panels Steel Framed Interior Sliding Door 60 in. x 81 in. Colonial White .	<b>DIVISION 8 - Doors and Windows</b>
<b>Manufacturer #</b> Home Depot – Contractor Wardrobe <b>Model #</b> COL-7281WH2R <a href="http://www.cwdoor.co">www.cwdoor.co</a> <b>Store SKU #</b> 429424	<b>Color /Finish :</b> Colonial White
<b>Description</b> The Colonial Bypass Door features a painted steel frame, prefinished raised 6-panel white hardboard and steel track and channel which provides your interior passageways with functionality and a classic look. Reversible door handing provides flexibility when installing. The Colonial door can also be used in commercial applications. <ul style="list-style-type: none"> <li>• Raised 6-panel colonial design</li> <li>• Prefinished gloss white hardboard panels</li> <li>• 2-1/4 in. deep steel top channel allows for more height adjustability</li> <li>• Bottom rolled 1-1/2 in. wheels on jump-proof steel track for durability and smoother operation</li> <li>• Integrated handle on frame molding for sleek uniform appearance and easy operation</li> <li>• Easy installation in minutes with simple hand tools</li> <li>• 60 in. x 81 in. fits width 58 in. - 61 in. and height 80.5 in. - 81.5 in.</li> <li>• Features prefinished vinyl hardboard panels</li> <li>• Painted steel frame, track and channel</li> </ul>	

Item: Ceramic – Floor bath room  
American Olean Weddington Russet Uniform Squares Mosaic Ceramic Floor and Wall Tile

DIVISION 9 - FINISHES

Manufacturer #  
Model# WD1022HC1Y2

Color /Finish  
Multi earth tones

**Description**

American Olean Weddington Russet Uniform Squares Mosaic Ceramic Floor and Wall Tile (Common: 12-in x 12-in; Actual: 11.87-in x 11.87-in)

Russet mosaic ceramic tile from the Weddington collection can be used on floors, walls and counters

Smooth surface creates an eye-catching sheen

PEI rating of 4 for moderate to heavy traffic in residential homes

Please inspect tile prior to installation, no adjustments will be allowed after installation

Vitreous tile is suitable for indoor use only

2-in x 2-in square mosaic tiles mounted on a 12-in x 12-in sheet

Durable, easy to clean and low maintenance



Item: Ceramic – Wall tile Accent  
American Olean Castlegate Universal Mosaic CG18

DIVISION 9 - FINISHES

Manufacturer # American Olean  
Model# CG18

Color /Finish  
Multi-earth tones

**Description**

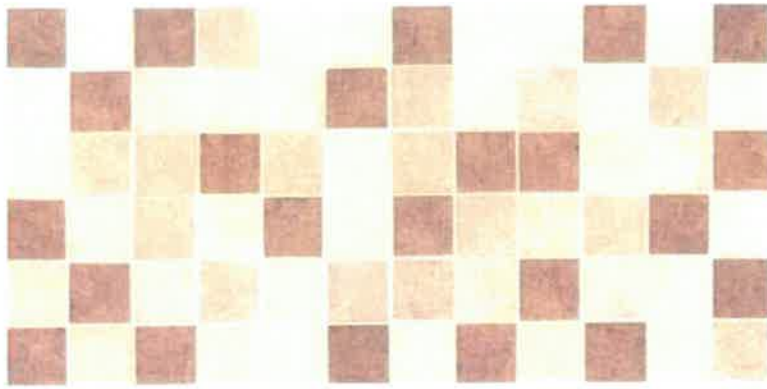
The soft colors emulate natural stone, but with the easy maintenance of tile.

Mosaic Tile Size: 2" x 2" (12" x 24" sheets)

Tile Thickness: 1/4"

Grout Joint Recommendation: 1/8"

Grout: Unsanded or Epoxy



Item: Ceramic - Wall tile

DIVISION 9 - FINISHES

Daltile Finesse Bright White 6 in. x 6 in. Ceramic Wall Tile (12.50 sq. ft. / case)

Manufacturer #

Model # FE0166HDIP

Color /Finish

Bright White

**Description**

Highly durable and one of the brightest whites you'll find in tile, the Finesse collection has multiple sizes and shapes to suit just about any ceramic wall tile project. This smooth, glossy 6 in. x 6 in. has a traditional format that's popular on backsplashes and feature walls in the kitchen and bathroom, as well as shower walls. It's a classic tile in a pure white color that is hard to find.

12.5 square feet, 50 pieces per case. Case weight is 35.64 lb.  
Grade 1, first-quality ceramic tile for backsplash and wall use  
Actual size: 5-15/16 in. width x 5-15/16 in. length x 1/4 in. thick

1 1/2" x 1 1/2" x 1/4"

Item: **Flooring Vinyl Tile**

**DIVISION 9 - FINISHES**

**Shaw Planks WANDERLUST 48in. x 6 in. Vinyl Tile**

**Manufacturer #**  
**Model# 715**

**Color /Finish**  
**715- Meridian**

**Description**

**Style Number**  
**Construction**  
**Size**  
**Thickness**  
**Wear Layer**  
**Finish**  
**Edge description**  
**SF per carton**  
**SF per pallet**  
**Installation**  
**Classification**

**BA982**  
**VersaLock**  
**6" x 48"**  
**3.2mm**  
**6mil**  
**OptiClean Urethane**  
**Square**  
**23.68**  
**2151.24**  
**Floating**  
**Good**

**Features**

- Water resistant

**RESILIENT**

**WANDERLUST**  
luxury vinyl plank



Item: Flooring Vinyl Tile

DIVISION 9 - FINISHES

### ARMSTRONG Planks - Brazilian Forest 36 in. x 6 in. Vinyl Tile

Manufacturer #  
Model# D2422

Color /Finish  
Brazilian cherry

#### Description

##### Specifications

Category	Flooring
Flooring Type	Vinyl Tile
Product Number	D2422
Collection	Planks - Brazil
Performance Class	Better
<b>Warranty</b>	Residential Warranty : 15 years Light Commercial Warranty : 7 years
Composition	Vinyl Composition
Wear Layer	Urethane No-Wax




## Planks - Brazilian Forest

36 in. x 6 in. Vinyl Tile

[Write a review](#) [Ask a question](#)

#### Colors:



<b>Item:</b> <b>Marble threshold 4x36"</b> <b>White Double Beveled 4 in. x 36 in. Engineered Marble Threshold Floor and Wall Tile</b>		<b>DIVISION 09 - FINISHES</b>
<b>Manufacturer #</b> <b>Model # THD2WH4X36DB</b>	<b>Color /Finish</b> <b>natural</b>	
<b>Description</b> <ul style="list-style-type: none"> <li>• 3 linear foot per piece, each piece sold individually. Piece weight equals 12 lb.</li> <li>• Grade 1, first-quality engineered marble threshold for floor and wall use</li> <li>• 4 in. width x 36 in. length x 3/4 in. thick</li> <li>• Polished smooth finish with a high sheen and slight variation in tone</li> <li>• PEI. Rating is not applicable for natural stone</li> <li>• Impervious flooring has water absorption of less than 0.5% for indoor or outdoor use and is frost proof</li> </ul>		
		

Item: Paint - Wall

DIVISION 9 - FINISHES

SW 6119 Antique White Eggshell Finish

Manufacturer #

Model# SW 6119 Antique White

Color /Finish

Antique White

Description

SW 6119

Interior / Exterior

Locator Number: 263-C6

263



COORDINATING COLORS

SIMILAR COLORS

DETAILS

SW 7012  
Creamy

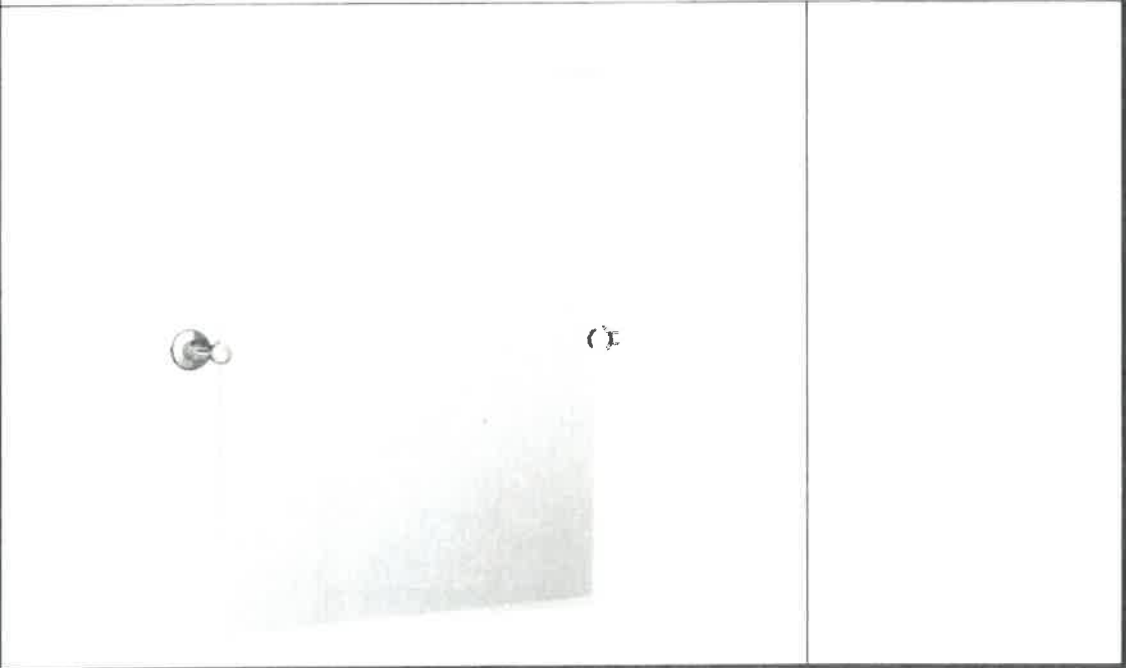
SW 6121  
Whole Wheat


SW 9114  
Falling Leaves



EXPLORE IN COLORSNAP® VISUALIZER

Item: Vinyl Composite Tile Armstrong VCT Fortress White		DIVISION 9 - FINISHES
Manufacturer # Product #: 51839	Color /Finish Multi earth tones on White	
Description American Olean Weddington Russet Uniform Squares Mosaic Ceramic Floor and Wall Tile (Common: 12-in x 12-in; Actual: 11.87-in x 11.87-in)		
Features & Details Size - 12" inch x 12" inch Thickness - 1/8" inch Covers 45 square feet /box Color Name: Fortress White Manufacturer: Armstrong ARM51839031 Collection: Standard Excelon Imperial Texture Floor Type: VCT		

Item: Wall Mount Rectangular Mirror in Chrome 31.5 in. L x 27.63 in. W	DIVISION 10 – Specialties ADA
Manufacturer # Home Depot – Gatco Max Collection Model # 4849S <a href="http://www.cwdoor.co">www.cwdoor.co</a>	Color /Finish :Chrome
<p><b>Description</b></p> <p>The Gatco Max Collection offers a range of elegant pieces to define your contemporary bathroom. Beautifully designed for modern appeal and finished in stylish chrome, this Wall Mount Rectangular Mirror features solid brass construction for lasting appeal. The mirror installs easily on your wall and makes a bright, elegant accent above any bathroom vanity.</p> <p>27.63 in. W x 31.5 in. H, perfect for display above a bathroom vanity          Solid brass construction provides lasting durability          Hand-polished chrome finish creates a sleek, timeless style          Designed for easy, wall-mounted installation</p>	
	

<b>Item: Mirror- Fixed Position Tilted Glass w/Stainless Steel Frame</b> <b>Bobrick B-293 2436 Mirror, 24" x 36" Fixed Position Tilted Glass w/Stainless Steel Frame</b>		<b>DIVISION 10 – Specialties</b> <b>ADA</b>
<b>Manufacturer #</b> B-293 2436	<b>Color /Finish</b> Glass w/Stainless Steel	
<b>Description</b> The Bobrick B-293 2436 is a fixed-position tilt mirror with a frame. This model has 24" W x 36" H (61 x 91 cm) dimensions. The frame is made of type 304 stainless steel and comes in a satin finish. This model is angled to provide visibility for people in wheelchairs. <ul style="list-style-type: none"> <li>• Dimensions: 24" W x 36" H (61 x 91 cm)</li> <li>• Frame material: 18-8 S, type 304, heavy-gauge stainless steel with satin finish</li> <li>• Tapers dimensions: From 4" (100mm) depth at top to 1" (25mm) depth at bottom</li> <li>• Mirror material: No. 1 quality, 1/4" (6mm) select float glass, selected for silvering</li> </ul>		
		

Item: Garbage Disposal  
InSinkErator Badger 1 Continuous Feed Garbage Disposal 1/3 HP

DIVISION 11- EQUIPMENT

Manufacturer #  
Model # BADGER 1

Color /Finish  
Galvanized steel construction

**Description**

The InSinkErator Badger 1 Continuous Feed Garbage Disposal 1/3 HP features a quick-mounting system that allows for easy installation or replacement. This sturdy garbage Disposal is constructed from galvanized steel and features a 26 oz. chamber for space-saving waste disposal. The garbage Disposal also features a 1/3 HP motor that rapidly grinds food waste for easy rinsing down the drain.

- Replacement is easy with the Quick Lock sink mount
- 1/3 HP Dura-Drive heavy duty induction motor
- Galvanized steel construction for dependability



Item: Range  
GE Freestanding 5-cu ft. Electric X

DIVISION 11- EQUIPMENT

Manufacturer #  
Model #JBS45DFWW

Color /Finish  
White (Common: 30-in)

Description

- ADA Compliant
- UL Listed
- CSA Approved
- ENERGY STAR®
- Made in America
- 

Specifications:

- Dimensions: 28" W x 64-3/4" H x 31-5/8" D
- Fresh Food Capacity: 11.55 Cu. Ft.
- Freezer Capacity: 3.89 Cu. Ft.
- Total Capacity: 15.5 Cu. Ft.
- Refrigerator Shelf Material: Wire
- Amperage: 15 Amps
- Voltage: 120 Volts
- Product Weight: 151 Pounds

GTE16DTH  
GE® ENERGY STAR® 15.5 Cu. Ft. Top-Freezer Refrigerator

Features and Benefits

- 2016 ENERGY STAR® qualified
- High-gloss handle - Provides a polished appearance that can be cleaned with ease
- Upright temperature controls - easy-to-use controls regulate both fresh food and freezer sections
- Full-width and multi-level adjustable wire shelves - Conveniently holds tall or odd-shaped items in the fresh food section
- Equipped for optional icemaker - Easily accommodates the installation of an icemaker
- Adjustable humidity drawers - Controls help food stay fresh
- Gallon door storage - Larger items are easily accommodated in the door
- Adjustable wire freezer shelf - Easily adjusts between two positions to accommodate items of all shapes and sizes
- Spillproof freezer floor - Seamless design of the freezer floor wipes up easily for quick cleanup
- Model GTE16DTHWW - White
- Model GTE16DTHCC - Black
- Model GTE16DTHR - Black



imagination at work



Specification Revised 8/24

Item: Range  
GE Freestanding 5-cu ft. Electric

DIVISION II- EQUIPMENT

Manufacturer #  
JBS45DFBB

Color /Finish  
Black (Common: 30-in)

**Description**

GE 5.0 cu. ft. Electric Range in Black with Storage Drawer cooks more dishes at once. Coil burners (2-2600 Watt and 2-1500 Watt) . Dual element bake in your oven produces even heat and great results. Lift-Up Cook top with Support Rods makes cleaning easy. GE appliances provide up-to-date technology and exceptional quality to simplify the way you live. With a timeless appearance, this family of appliances is ideal. Coming from one of the most trusted names in America, you know that this entire selection of appliances is as advanced as it is practical.



**Features:**

- Upfront controls
- Minimize need to reach
- 5.0 cu. ft. oven capacity
- Cook more dishes at once
- Standard clean oven
- Smooth surface and rounded corners make clean-up quick and easy
- Coil heating elements Provide even heat and easy cleanup
- Removable full-width storage drawer  
Store cookware or kitchen accessories

ADA Compliant

Designed to be accessible and  
easy to open

Item: Range  
GE Freestanding 5-cu ft. Electric X

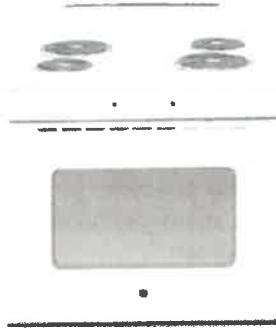
DIVISION 11- EQUIPMENT

Manufacturer #  
Model #JBS45DFWW

Color /Finish  
White (Common: 30-in)

**Description**

GE 5.0 cu. ft. Electric Range in White with Storage Drawer cooks more dishes at once. Coil burners (2-2600 Watt and 2-1500 Watt) . Dual element bake in your oven produces even heat and great results. Lift-Up Cooktop with Support Rods makes cleaning easy. GE appliances provide up-to-date technology and exceptional quality to simplify the way you live. With a timeless appearance, this family of appliances is ideal. Coming from one of the most trusted names in America, you know that this entire selection of appliances is as advanced as it is practical.



**Upfront Controls**

Minimize need to reach.

**5.0 cu. ft. Oven Capacity**

Cook more dishes at once.

**Standard Clean Oven**

Provide even heat and easy cleanup.

**Dual-Element Bake**

Upper and lower elements produce even heat and great results.

**Removable Full Width Storage Drawer**

Convenient drawer can be used for storing cookware or kitchen accessories.

Item: BATH Faucet  
Delta Foundations Core B Lavatory Faucet Chrome Single Handle With Pop-Up

DIVISION 15 - Mechanical

Manufacturer #  
Mfg #B510LF

Color /Finish  
Chrome

**Description**

Delta(R) Foundations Core-B Single Handle Bath Faucet With Pop-Up - Chrome Finish - Washerless Function - With Metal Pop-Up - Ultra Low Lead - 1.5 GPM @ 60 PSI - Mfg #B510LF

BRASS CRAFT - CR19C ANGLE STOPS, 51-12A BRAIDED  
STAINLESS STEEL SUPPLIES AND 649SS ESCUTCHEONS, KEENEY  
5700PC OFFSFT TYPE GRID DRAIN AND 5463XPC CAST BRASS TRA



Item: Elongated Toilet Bowl ADA American Standard® Cadet® PRO Elongated Toilet Bowl ADA		DIVISION 15 - Mechanical
Manufacturer # Mfg #3517.A101	Color /Finish white	
<b>Description</b> American Standard® PRO Cadet® 1.28 GPF Toilet Bowl - Virtually Eliminate Call-Backs For Clogged Toilets And Get A Toilet With A Sleek, Modern Design - Toilet Bowl, Tank Sold Separately - Elongated Bowl (ADA) - 2-1/8" Trapway With EverClean™ Antimicrobial Finish And PowerWash™ Rim That Scrubs Bowl With Each Flush - 16-1/2" Bowl Height, Meets ADA Requirements - 12" Rough-In Or 10" Rough-In When Used With 404765 Tank - Uses 20% Less Water Than Standard 1.6 GPF Toilet - 5-Year Warranty - Use With American Standard Cadet PRO Toilet Tank Only (698572 1.6 GPF; 404776 1.28 GPF; 696581 Right-Hand Trip Lever 1.28 GPF; 404765 10" Rough-In 1.28 GPF) - Mfg #3517.A101		
Name American Standard® Cadet® PRO Elongated Toilet		

Item: Kitchen Faucet  
Delta Foundations Core B Kitchen Faucet Chrome Single Handle

DIVISION 15 - Mechanical

Manufacturer #  
Mfg #B1310LF

Color /Finish  
Chrome

Description

Delta® Foundations Core-B Single Handle Kitchen Faucet - Chrome Finish - Washerless Function - 1.8 GPM @ 60 PSI - Less Spray - Mfg #B1310LF



Item: Shower Valve  
Delta R10000-UNWS MultiChoice Universal Tub and Shower Valve Body

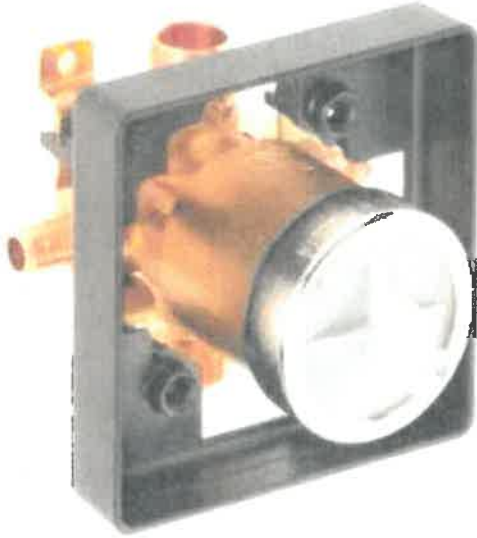
DIVISION 15 - Mechanical

Manufacturer #  
R10000-UNWS

Color /Finish  
Cast metal

**Description**

Valve body only  
1/2" universal inlets accept 1/2" copper, 1/2" iron pipe, PEX or CPVC adapters  
1/2" universal outlets, inlets/outlets have male threads  
Back-to-back capability  
BX=single box model  
BXT=single box model, thin wall mounting kit included  
WS=with stops, single box model  
Lifetime Faucet and Finish Warranty



Item: Toilet tank  
American Standard® Cadet® PRO 1.28 Gallon Toilet Tank - 12" Rough-In


DIVISION 15 - Mechanical

Manufacturer #  
Mfg#4188.A104

Color /Finish  
Chrome

**Description**

American Standard® Cadet® PRO 1.28 GPF Toilet Tank - Virtually Eliminate Call-Backs For Clogged Toilets And Get A Toilet With A Sleek, Modern Design - Toilet Tank, Bowl Sold Separately - 3" Flush Valve, Fluidmaster® Brass Shank Fill Valve, Brass Tank Lever - Left-Hand Tank - 12" Rough-In - Uses 20% Less Water Than Standard 1.6 GPF Toilet - 5-Year Warranty - Use With American Standard Cadet PRO Toilet Bowl Only (404781 Round, 189818 Round ADA, 404768 Elongated, 404767 Elongated ADA, 404766 14" Rough-In Elongated ADA) - Mfg#4188.A104

<b>Item:</b> Tub/Shower, Trim, <b>Delta</b> Tub/Shower, Trim, Lever Handle, Chrome ADA	DIVISION 15 - Mechanical
<b>Manufacturer #</b> Mfr #: T13420	<b>Color /Finish</b> Chrome
<b>Description</b> <b>Product Details</b> Classic, sensible styling that complements any home <b>Handle included</b> Single lever handle for ease of temperature and volume control Monitor® Scald-guard® valve keeps water temperature within +/-3°F For use with MultiChoice Universal rough valve body Order MultiChoice Universal rough-in separately , See Sec Easy-to-clean, Touch-Clean® showerhead provides full spray pattern	
	

Item: Under Sink Protector ADA  
Plumberex Pro-Extreme™ Sink Tubular ADA Cover

DIVISION 15 - Mechanical

Manufacturer #  
Mfg #x4333

Color /Finish  
White PVC

**Description**

Plumberex Pro-Extreme™ Under Lav Protector - Insulates Drain And Supply Lines Under Lavatories To Protect Persons Confined To Wheelchairs - 100% Molded PVC With Antimicrobial Agents - One-Piece Design With Tamper Resistant Snap-Lock Fasteners - Fits Brass/Plastic 1-1/4" And 1-1/2" P-Traps - ADA 4.19.4 And ANSI 117.1 Compliant - Made In USA - Meets All Plumbing Codes But Not Fire And Building Codes - ASME 18.9 - Code Requires Covering P-Trap Drain And Both Hot & Cold Water Supplies, - Mfg #x4333

Home Plumberex Pro-Extreme™ Sink Tubular ADA Cover

Item: Bath tub  
 Bootz® Enameled Steel Bathtub - Right-Handed Drain/ Left-Handed Drain - Self-Leveling For Easy Install - White - 5' Standard Design - 60W x 30D x 14-1/4"H - Mfg #011-2364

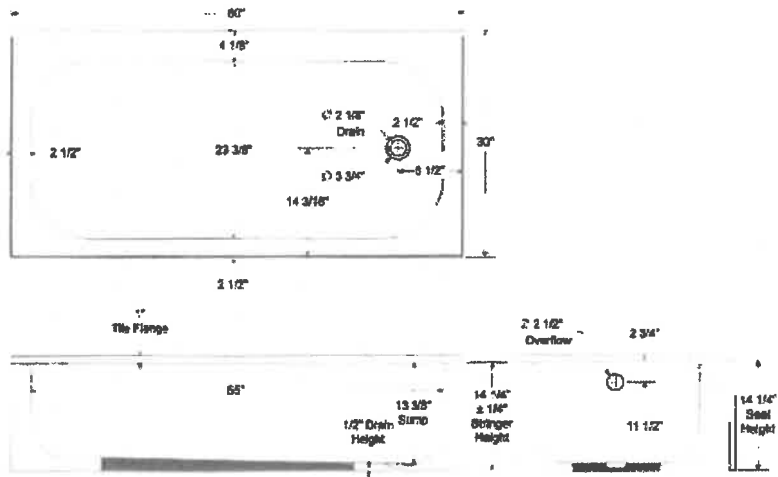
DIVISION 15 - Mechanical

Manufacturer #  
 Mfg #GE125213  
 011-2364 RH Drain, slip resistant bottom  
 011-2365 LH Drain, slip resistant bottom

Color /Finish  
 white

Description  
 Bootz® Enameled Steel Bathtub - Right-Handed Drain - Self-Leveling For Easy Install - White - 5' Standard Design - 60W x 30D x 14-1/4"H - Mfg #011-2364

**5' Aloha - Bathtub: 011- 2360, 2361, 2364, 2365**



Product Type: Bathtub  
 Brand: Bootz  
 Collection: Aloha  
 ADA Compliant: ADA Compliant  
 Capacity: 39 gal  
 Color: White  
 Commercial -  
 Residential: Residential  
 Configuration: Right Hand  
 Connections: Conventional Installation  
 Dimensions: 60 in X 30 in X 14-1/4 in  
 Material: Porcelain / Steel  
 Mount: Alcove  
 Shape: Rectangular  
 Size: 5 ft

Item: 15 Amp Decorator Receptacle - White - Package of 10 DIVISION 16 - ELECTRICAL

Manufacturer # Part #: 336403 Color /Finish White

Description  
15 Amp Single Pole Wall Switch - White - Package Of 10  
  
15 Amp Decorator Receptacle "Pkg Of 10" - 125 Volt - Quickwired And Side Wired - Nylon - White - Use With Copper Wire Only



<b>Item: Elongated Toilet Bowl ADA</b> <b>American Standard Laurel Elongated Toilet Seat with Cover, White</b>		<b>DIVISION 15 - Mechanical</b>
<b>Manufacturer #</b> 5311.012.020	<b>Color /Finish</b> white	
<b>Description</b> American Standard Laurel EL Molded Wood Seat and Cover provides the classic design perfect for any style. Additional Features: High-gloss molded wood seat Closed elongated seat with cover Laurel seat and cover Bolts and dual-faced adhesive washers Fits any elongated toilet. Durable molded wood construction. American standard toilet seats. Complete with bolts and dual-faced adhesive washers. Closed, elongated seat with cover. Fits any elongated toilet. Choose from several color options. Overall dimensions: 18L x 14.25W x 2.75H in..		

Item: Hand Shower  
**Delta® Activotouch Slide Bar Hand Shower ADA**

DIVISION 15 – Mechanical  
**ADA**

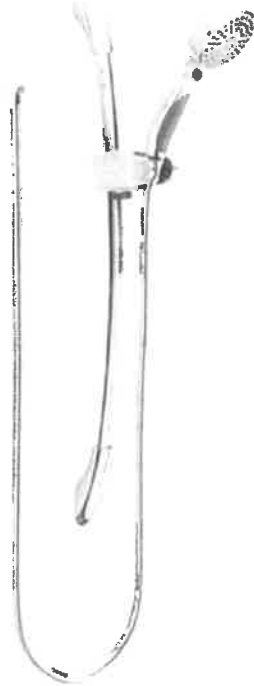
Manufacturer #  
Mfr #51504


Color /Finish  
Chrome

**Description**  
Shower

Delta® Activotouch Slide Bar Hand Shower - Chrome Finish - Nine-Setting Hand Shower - Features Touch-Clean® Spray Holes - 60" - 82" Stretchable Metal Hose - 28" Wall Bar W/Adjustable Slide - Push Button Spray Selection - 2.5 GPM @ 80 PSI - Mfg #51504

Delta  
9-Spray Slide Bar Hand Shower in Chrome



Item: Kitchen Sink ADA 25 x 21-1/4" Single Bowl Stainless Steel Kitchen Sink 3-Hole 5-3/8" Depth		DIVISION 15 - Mechanical
Manufacturer # Mfg #GE125213	Color /Finish Satin Finish	
Description Aspen® 25W x 22"L ADA Single Bowl Stainless Steel Sink - Three Hole - 6" Depth - 21 Gauge - Rear Right Drain - Satin Finish - Integrated Mounting System - ADA Compliant - Sound Deadening Bottom - Standard 3-1/2" Drain -		
<a href="#">Home</a> ADA 25 x 21-1/4" Single Bowl Stainless Steel Kitchen Sink		
		

Item: Kitchen Sink  
ADA 25 x 21-1/4" Single Bowl Stainless Steel Kitchen Sink 3-Hole 5-3/8" Depth

DIVISION 15 - Mechanical

Manufacturer #  
Mfg #GE125213

Color /Finish  
Satin Finish

Description  
Aspen® 25W x 22"L ADA Single Bowl Stainless Steel Sink - Three Hole - 6" Depth - 21 Gauge - Rear Right Drain - Satin Finish - Integrated Mounting System - ADA Compliant - Sound Deadening Bottom - Standard 3-1/2" Drain -

Aspen 25 x 22" Single Bowl Stainless Steel Kitchen Sink



Item: **Folding Universal Sliding Transfer Bench - ADA**

**DIVISION 15 - Mechanical**

Manufacturer # **Drive Medical**  
RTL12075

Color /Finish  
**White /Aluminum**

Description <http://www.drivemedical.com/index.php/folding-universal-sliding-transfer-bench-253.html>  
The new **Folding Universal Sliding Transfer Bench** from Drive Medical offers your customers an easy way to transfer in and out of the tub. The bench slides left and right along the frame, and comes equipped with a seat belt for added safety.

Seat Dimensions	27 1/2" (W) x 18 1/2" (D)
Height	21" - 25"
Weight	16 lbs.
Carton Shipping Weight	20 lbs.
Weight Limit	300 lbs.
Warranty	Limited Lifetime

RTL12075



#### Features

- Comes with safety net under seat to prevent the dropping of soap, shampoo, etc.
- Folds flat for transport and storage.
- Seat belt for added safety.
- Standard removable snap disc.
- Transfer Bench slides left and right along frame for easy entry into and out of tub.

Item: Refrigerator

GE® 15.5 Cu. Ft. Top-Freezer Refrigerator ENERGY STAR®

DIVISION 11- EQUIPMENT

Manufacturer #

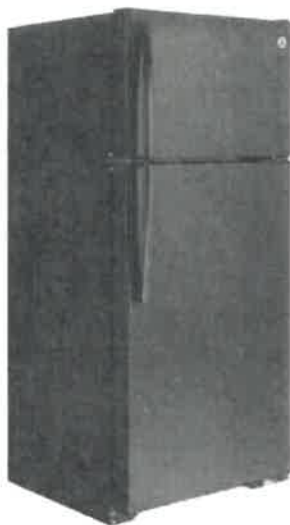
Model #: GTE16DTHBB

Color /Finish

Black

### Description

GE® 15.5 Cu. Ft. capacity top freezer energy star qualified refrigerator is perfect for any kitchen setting. It features upfront temperature controls which are easy to use controls that regulate both fresh food and freezer sections. Additionally, it features adjustable wire shelves. These moveable racks can handle a variety of foods easily. The clear drawers on this refrigerator make finding your favorite items quick and easy.



### Features:

- Energy Star Rated This refrigerator meets the Energy Star guidelines for energy efficiency.
- Upfront Temperature Controls
- Easy-to-use controls regulate both fresh food and freezer sections
- Conveniently holds tall or odd-shaped items in the fresh food section.
- Adjustable-Humidity Drawers
- Controls helps food stay fresh.
- Gallon Door Storage
- Larger items are easily accommodated in the door.
- Wire Freezer Shelf
- Provides additional storage for frozen foods.
- #1 in Quality and Dependability: Among 14-18 cu. ft. refrigerators based on an independent study of property maintenance personnel.
- Adjustable wire freezer shelf: Easily adjusts between two positions to accommodate items of all shapes and sizes

OVERALL DIMENSIONS	Height to top of hinge (in.) A	84-3/4
	Height to top of case (in.) B	84-1/4
	Case depth without door (in.) C	25-3/4
	Case depth less door handle (in.) D	29-1/2
	Case depth with door handle (in.) E	31-5/8
	Depth with fresh food door open 90° (in.) F	55-7/8
	Width (in.) G	28
	Width with door open 90° with door handle (in.) H	30-5/8
AIR CLEARANCES	Each side (in.)	3/4
	Top (in.)	1
	Back (in.)	2

ADA Compliant  
Designed to be  
accessible and  
easy to open.



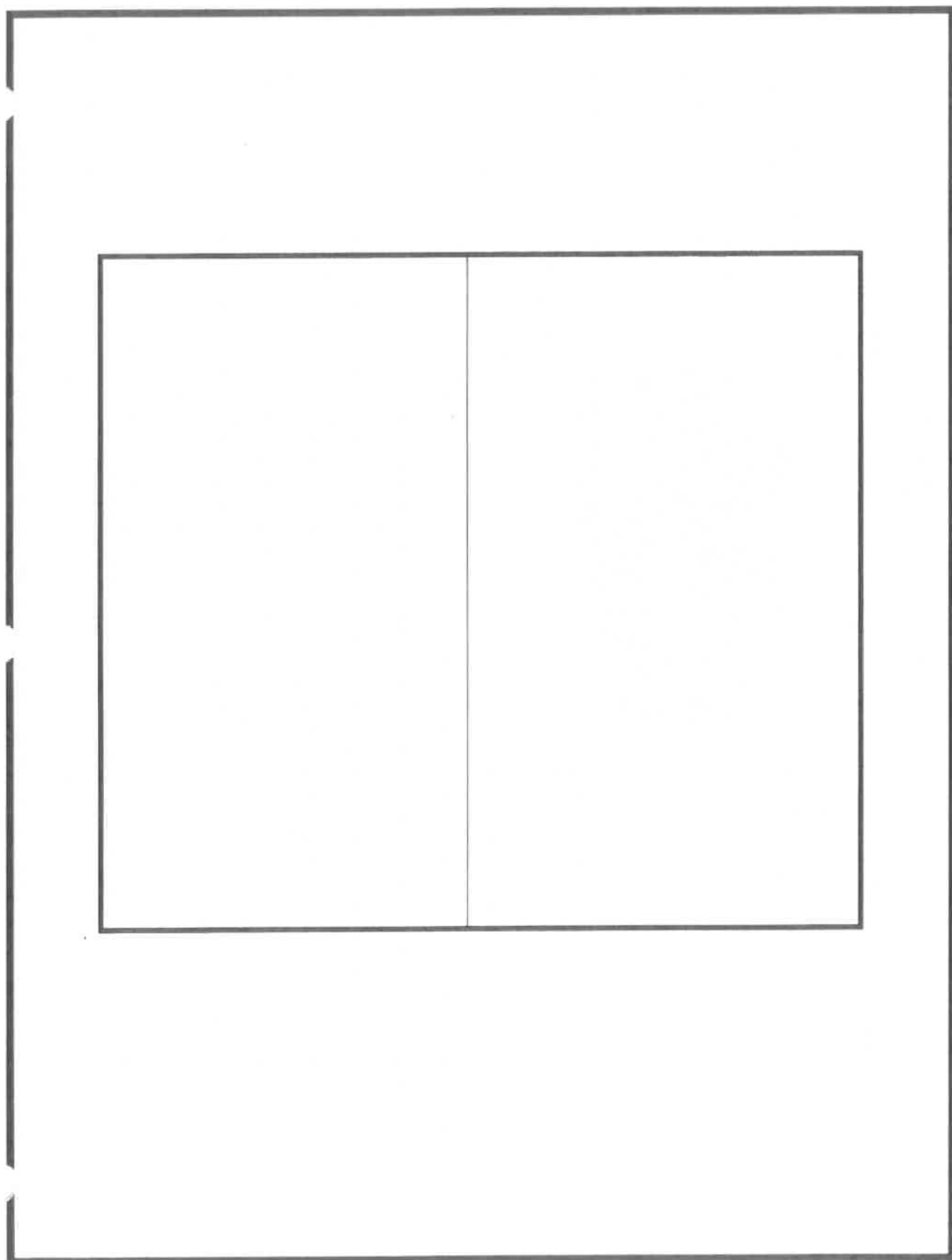
ENERGY  
STAR  
Qualified



Made in  
America  
70 to 90% LDC

Product details  
at

[www.ge.com](http://www.ge.com)



Item: Refrigerator  
GE 14.6 cu. ft. Top Freezer Refrigerator

DIVISION 11- EQUIPMENT

Manufacturer #  
Model #:GTE15CTHRWW

Color /Finish  
WHITE

**Description**

GE's 14.6 cubic feet capacity top freezer energy star qualified refrigerator is perfect for any kitchen setting. It features upfront temperature controls which are easy to use controls that regulate both fresh food and freezer sections. Additionally, it features adjustable wire shelves. These moveable racks can handle a variety of foods easily. The clear drawers on this refrigerator make finding your favorite items quick and easy. There's also an optional ice maker for this fridge (IM4A Ready).



**Features:**

- Upfront temperature controls
- Easy-to-use controls
- Adjustable wire shelves
- Moveable racks can
- Clear drawers
- Transparent drawers
- Gallon door storage
- Larger in the door bins
- Adjustable wire freezer shelf
- Provides additional storage for frozen foods
- #1 in Quality and Dependability
- 1-UL Listed, ADA Compliant

Item: Wall Hung Lavatory ADA  
 Seasons® White China Wall Hung Lavatory - 17-3/8" x 19-1/8" - 4" Centers - Front  
 Overflow

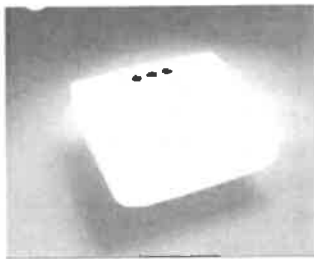
DIVISION 15 - Mechanical

Manufacturer #  
 Mfg #GE125213

Color /Finish  
 white

**Description**

White vitreous china wall hung lavatory  
 Front over flow  
 17-3/8 in. x 19-1/8 in.  
 ADA compliant



**Wall Mount Lavatory**

**PRODUCT FEATURES**

- Vitreous China
- 19-1/8" x 17 3/8" Rectangular
- 4" Centers
- Front Overflow
- ADA Compliant
- Available in White or Beige

**CERTIFICATIONS**

**WARRANTY**

- One Year Limited Warranty
- See Other Warranty Additional



Wall Mount Lavatory  
 4" Center



Item: GFCI

DIVISION 16 - ELECTRICAL

Hubbell Circuit Guard® 15A GFCI Receptacle With Matching Nylon Wallplate,  
White

Manufacturer #  
Mfg #GF15WLA

Color /Finish  
White

**Description**

Hubbell 15 Amp Circuit Guard® Lighted GFCI Duplex Receptacle - 125 Volt - 20 Amp Feed-Through - NEMA 5-15 - Back And Side Wired - Color-Matched Test And Reset Buttons - With Wall Plate - White - Mfg #GF15WLA



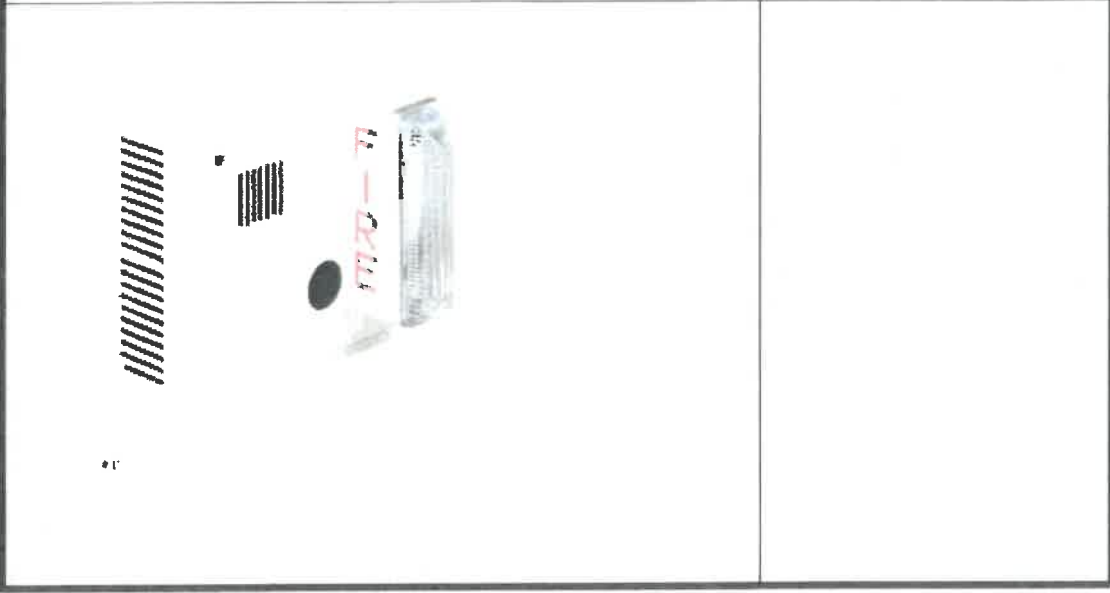
Item: Fire Alarm Systems Smoke Alarm ADA  
120VAC/9VDC Direct Wire Cord Smoke Alarm With ADA Compliant Strobe


DIVISION 16 - ELECTRICAL


Manufacturer #  
Mfg #7139CS-W


Color /Finish  
White


Description  
Direct Wire Cord Smoke Alarm With ADA Compliant Strobe - 120 VAC Direct Wire With 9VDC Battery Backup - Photoelectric Smoke Alarm - Temporal 3 Sounder - Includes 177 Candela ADA Compliant Strobe - Includes 1 Set Form A/Form C Relay Contacts - Tandem Interconnect Capabilities With Other Gentex Alarms - Low Or Missing Battery Indicator - Wall Mount - Mfg #7139CS-W



Item: Smoke and Carbon Monoxide Alarm with Battery Backup Alarm Sensor Type : Ionization		DIVISION 16 - ELECTRICAL
Manufacturer : <b>Kidde</b> <b>i12010SCO or Approved Equal</b>		Color /Finish White / Plastic
<p><b>Description</b></p> <p>The <b>Kidde i12010SCO</b> is a hardwired combination smoke and carbon monoxide (CO) alarm. It features a sealed lithium battery back-up for worst case scenarios when the power line is disconnected. This battery is tamper-proof and lasts for 10 years for a long-lasting, worry-free operation. When the battery is at the end of its life, it will chirp so that this alarm can be replaced.</p> <p>This Kidde carbon monoxide and smoke detector uses state-of-the-art technology to detect smoldering flames, fast flaming and carbon monoxide build-up. This alarm uses sensor technology that combines ionization and electrochemical sensors to successfully detect threats. This intelligent sensor technology also reduces the chance of a nuisance alarm occurring.</p> <p>When triggered, this alarm uses a voice warning system to announce the type of threat, allowing for an appropriate response. It can be connected to up to 24 Kidde devices for whole home protection. It also features a green LED light that shows when this alarm is properly connected.</p>		
<ul style="list-style-type: none"> <li>• Power Source: 120VAC, 60Hz 45mA max per alarm. Sealed lithium battery backup</li> <li>• Sensor: Sensor: Ionization</li> <li>• CO Sensor: Electrochemical</li> <li>• Audio Alarm: 85dB at 10ft</li> <li>• Temperature Range: 40°F (4.4°C) to 100°F (37.8°C)</li> <li>• Humidity Range: 10%-95% relative humidity, non-condensing</li> <li>• Size: 5.5" in diameter x 1.75" depth</li> <li>• Interconnects: Up to 24 Kidde devices (of which 18 can be initiating)</li> </ul>		

Item: Smoke Alarm with 10 year Battery Backup Alarm Sensor Type : Ionization		DIVISION 16 - ELECTRICAL
Manufacturer : <b>Kidde</b> <b>Kidde i12010S</b>	Color /Finish White / Plastic	
<p><b>Description</b></p> <p>The Kidde i12010S is a hardwired 120V smoke alarm. It features a sealed lithium battery back-up for worst case scenarios when power to this device is disconnected. This battery is sealed-in and lasts for 10 years for a long-lasting, worry-free operation. As it is intended to work for 10 years, the homeowner doesn't have to worry about battery replacement in this time period. When the battery is at the end of its life, it will chirp so that this alarm can be replaced.</p> <p>This Kidde smoke detector uses state-of-the-art technology to detect harmful smoke build-up. This alarm uses ionization sensing technology, which helps detect invisible fire particles associated with flaming fires as opposed to photoelectric sensors that detect visible smoke particles. It is recommended that both ionization and photoelectric alarms are installed throughout the home to insure maximum detection. This model features a dust cover that protects the unit from contaminants when installing, which reduces the chance of a nuisance alarm occurring down the line. This alarm can be connected to up to 24 Kidde devices, including carbon monoxide (CO) and heat alarms, for whole home protection.</p>		
<ul style="list-style-type: none"> <li>• Power Source: 120VAC (60 Hz, 45mA Max)</li> <li>• Sensor: Ionization</li> <li>• Audio Alarm: 85dB at 10ft</li> <li>• Temperature Range: 40°F (4.4°C) to 100°F (37.8°C)</li> <li>• Humidity Range: Up to 95% relative humidity (RH), non-condensing</li> <li>• Size: 5.5" in diameter x 1.75" depth</li> <li>• Interconnects: Up to 24 Kidde devices</li> </ul>		

<b>Item:</b> 15 Amp Decorator Wall Receptacle		<b>DIVISION 16 - ELECTRICAL</b>
<b>Manufacturer #</b> Mfg #RRD15W	<b>Color /Finish</b> White	
<b>Description</b> Hubbell 15 Amp Decorator Duplex Wall Receptacle - 125 Volt - Double Pole - Three Wire - NEMA 5-15R - Push And Side Wired - White - Nylon - Use With Copper Wire Only - Mfg #RRD15W		
<a href="#">Home</a> 15 Amp Decorator Receptacle - White - Package of		
		

<b>Item:</b> <b>15 Amp Single Pole Wall Switch - White -</b>		<b>DIVISION 16 - ELECTRICAL</b>
<b>Manufacturer #</b> <b>Part #: 336406</b>	<b>Color /Finish</b> <b>White</b>	
<b>Description</b> <b>15 Amp Single Pole Wall Switch - White - Package Of 10</b>  <b>15 Amp Decorator Wall Switch "Pkg Of 10" - 120 Volt - Single Pole - Ground Screw - Quickwired and Side Wired - Use With Copper Wire Only - White</b>		
		

7

<b>Item:</b> Decorator Wall Plate Single Gang Decorator Wall Plate - White - Package Of 10		<b>DIVISION 16 - ELECTRICAL</b>
<b>Manufacturer #</b> Part #: 336037	<b>Color /Finish</b> White	
<b>Description</b> Single-Gang Decorator Wall Plate "Pkg Of 10" - Unbreakable Polycarbonate - Captive Screw - White - 2-3/4W x 4-1/2"H		
<small>HOME</small> Single Gang Decorator Wall Plate - White - Package		